

# The *FLASH*

JANUARY 2016 | ISSUE 455



**OFFICIAL PUBLICATION OF THE AUSTIN HEALEY SPORTS & TOURING CLUB**

# CONTENTS



# THE FLASH

[www.austin-healey-stc.org](http://www.austin-healey-stc.org)

## CORPORATE OFFICERS

President: Ray Donovan  
Membership: Rick Brodeur  
Secretary: Del Border  
Treasurer: Gerry Kunkle  
Flash Editor: Steve Jekogian

## HARRISBURG REGION

President: Joe Spear  
Editor: Fred Bennett

## LEHIGH VALLEY REGION

President: Ken Beck  
Editor: Mike Bradley

## PHILADELPHIA REGION

President: John Heffron  
Editor: Randy Alkins

## BRANDYWINE REGION

President: Chuck Ott  
Editor: Ernie Leser

## NORTH JERSEY REGION

President: Ian Kessen  
Editor: Steve Feld

## LONG ISLAND REGION

President: Paul Parfrey  
Editor: Paul Parfrey

Copyright 2016 AHSTC©

## Contents

- 3 CLUB | Editor
- 4 ARTICLE | Tribute to John Morrison
- 6 REGION | Philadelphia
- 7 REGION | Brandywine
- 9 REGION | Harrisburg
- 11 REGION | Long Island
- 12 REGION | North Jersey
- 13 REGION | Lehigh Valley
- 15 ARTICLE | History of the Club
- 23 CLUB | Members Corner
- 24 CLUB | ENCOUNTER 2015
- 26 ARTICLE | ENCOUNTER  
YESTERDAY & TODAY
- 28 CLUB | Business
- 31 ARTICLE | Seats Stuck!
- 32 CLUB | Membership Application
- 33 CLUB | Directory

## ON THE COVER

John Morrison  
1947 to 2015



# What's In The Flash

Steve Jekogian

*Sad news everyone,*

*We just received information that John Morrison passed away on December 12th.*

*Services and interment were private and held December 14th.*

*Arrangements by Brown Funeral Home.*

*In lieu of flowers, donations in John's name to a local animal rescue would be deeply appreciated.*

*Online condolences may be offered at Brown Funeral Home, WV.com*

*See more at: <http://www.legacy.com/obituaries/eveningsun/obituary.aspx?n=John-Morrison&pid=176890811#sthash.1vMSHWxz.dpuf>*

*John was a key and founding member of the AHSTC. He was president for many years and led the club and help nurture, and guided the club for over 40 years.*

*An event will be held for John by Dawn*

*It's never the right time to lose a nagrivorator (oops!) navigator. You are cordially invited to come together for an afternoon of booze, bites, and blarney as we reminisce about that irascible rascal...*

*Saturday, January 9, 2016 at 2 PM*

*Clarion Hotel and Conference Center - Shepherdstown  
Shepherdstown, West Virginia*

*John and Dawn moved recently to the below address.*

*Dawn Brickley*

*269 Pathfinder Lane*

*Hedgesville West Virginia 25427*

January 2016, you made to another year. That means your Healey is just older (and so are you). Winter is the best time to correct all those "little" projects you could never get to during driving time.

Check out the tech articles in this issue. Also, please remember the tech articles in previous issues of the Flash like October 2015---- Mounting and Installation of 3rd Brake Light

Many of the tech articles are also on the AHSTC web site [www.austin-healey-stc.org](http://www.austin-healey-stc.org)





*As Donald Healey and Gerry Coker produced a legendary marque that we all enjoy,  
John's legacy is the AHSTC Club we all enjoy..*



# TRIBUTES TO JOHN MORRISON

*By Del Border*

**J**ohn Morrison is well-known as a founding member of the Austin-Healey Sports & Touring Club. In my mind, I think that John is THE founder of the AHSTC. Without his vision and dedication, there might not be an AHSTC.

John first met with George and Joan Null in early 1977 to discuss starting a club for Austin-Healeys. There were one or two others in the early discussions, but they dropped out early and I do not recall their names. In 1977, John and the Nulls called people they knew who owned an Austin-Healey and set up a first meeting at a pizza place near Harrisburg – Dante’s. Attending were John, the Hoffers and the Borders – I’m not sure if anyone else attended that first meeting since we picked up more people at each subsequent meeting.

John and I found out that we both worked for Dentsply International, John as a programmer in IT and me as an engineer for dental equipment. At the time, I had access to Dentsply’s prototype machine shop which had a large ultra-sound parts cleaner. The liquid solution in the ultra-sound cleaner was changed every several months, and the mechanics would let me know that I could bring in dirty car parts before they changed out the solution. Between John and me, we found out that the cleaner was large enough to clean parts from 5 carburetors at a time.

We continued to meet at Dante’s for several months, discussing where we wanted to go with the club as well as coming up with a name for the club. During one of the meetings, Joan Null suggested having a gathering just for Austin-Healeys to promote the club and to get additional members. The first meet, called Encounter, was held in 1978 at the Hershey Lodge in Hershey, PA, where approximately 75 Healeys showed up.

The meet was consistent with today’s Encounter, consisting of a car show, regalia, rallye and funkhana. The funkhana itself consisted of three separate events and John was my co-driver. He was also my co-driver at one other Encounter - the “Bombay Hilton” in Landisville, PA.

During the first several years of AHSTC, John was President of the Harrisburg Region, instigated creation of AHSTC By-Laws, created a membership spreadsheet that is being used to this day, started the AHSTC newsletter (“Old Yeller”) in his basement and held meetings in his house and came up with the idea of creating separate Regions. After the AHSTC Regions were created, John became the first Corporate President of AHSTC.

John was a fixture at Encounters in his Mickey Mouse t-shirt and always made it a point to attend the Corporate Board meetings to add his input as far as where the club was headed. John was considered the “Elder Statesman” at the Board meetings and when John spoke, people listened.

John left us far too early and I am grateful that I got to know (and party with) John for almost 40 years and am lucky to consider him to be one of my close Healey friends.

*By Don Olsen*

If you are blessed once in a lifetime you will meet someone who will become a friend and mentor. You experience that special spark that begins your journey together. Such was the introduction between John Morris and me.

He was the brother I never had. He brought sunshine and humour into my life. Through Austin Healeys and AHSTC we grew close together and I learned insurmountable knowledge about its makers’ history and racing prowess.

The highlights were retrievals-New York and Delaware in the ice and snow and in the York/Harrisburg area and the close proximity. Get a case of beer and say “retrieval” and John was there. His vision and support resulted in the rapid growth needed for the AHSTC to be a recognized club in the Healey world.

He came into my life as a gift. He left his footprints on my heart and will always be a part of me. Rest in peace John!



# PHILADELPHIA

REGION



The New Year fast approaches and we are busy readying the cars for a long winter nap. Bounce dryer sheets are strategically placed to ward off critters from finding soft cushy homes.

November's meeting at the Metropolitan was well attended with good food and good company. John Heffron distributed the "Healey Marque" magazine that featured Enclave 2015 in Gettysburg. Marlyn and I were happily surprised to see our Sprite in the magazine.

We discussed possible upcoming events, including a tour of the Simeone Museum, a weekend tour at St. Michael's, Maryland, the Delaware Water Gap, and a ride down the west coast of New Jersey, including Salem and Cape May Counties.

This past Saturday, December 12th, our annual Christmas party was held at John Heffron and Sandy Nairn's lovely home in Moorestown, NJ. The house is in a beautiful setting with decorations abounding everywhere, inside and out. The impressively decorated Christmas trees put us into the spirit of the season.

The food and beverages were abundant and delicious, and camaraderie warmed the home. About 35 guests enjoyed a dinner of glazed chicken, roasted vegetables, pumpkin ravioli, roasted potatoes, complete with all the trimmings for a holiday meal. After dinner we were treated to a scrumptious variety of desserts.

The tables were cleared and the holiday gift fun began. Many wrapped gifts awaited lucky individuals to select and to "steal" from others. Lois again seemed to select gifts that others took from her, but in the end, she was able to keep what she liked. This part of the evening was also great fun, and everyone laughed and had a good time.

The next meeting is Monday, January 18, 2016, at the Metropolitan. We wish everyone a happy and healthy New Year! 



## Motorcar Garage

Repair-Maintenance-Restoration

British Car Specialist

Peter Cosmides

42 North Pine Ave.  
Maple Shade, NJ 08052

Phone: 856-667-6657



[www.Motorcar-Garage.com](http://www.Motorcar-Garage.com)

 BRITISH MOTOR TRADE ASSOCIATION

# Brandywine REGION

**O**ur annual elections were held on Thursday November 12th at Stoney's British Pub in Wilmington. Attending were Pete Roberts; Jeff and Lisa Lanno; Chuck Ott; Jim Martin; Kris and Steve Garrett; Buz Marshall; Mike, Elizabeth, Tom and Diane Zalewski; Joan and myself.

After enjoying the varied British cuisine and beer, Chuck reviewed the recent AHSTC board meeting happenings. Enclave was a great success. The fantastic number of pristine cars, the excellent accommodations, historical setting, and a very good financial return. Each of the regions did benefit from the latter in proportion to their involvement in the event. An increase in member rebates was also decided upon.

Some discussion took place concerning Encounter 2016 which we will be hosting. Chuck Ott will be issuing monthly updates during the year concerning the event.

Results of the election are shown below. The Events Coordinator position is open. For the time being, each event will be handled by the person closest to it.

***President: Chuck Ott***

***Treasurer: Pete Roberts***

***Events Coordinator: open***

***Membership: Diane Zalewski***

***Flash Editor and Club Taster: Ernie Leser***

***Sargent at Arms: Kris Garrett***

Jeff Lanno and Chuck Ott attended the British Car Swap meet at K&T Vintage Sports Cars on November 29th. Chuck reports that he did sell some of his excess parts while in turn acquiring ones that he needed. Jeff also bought some parts for his Healey. A tour of Jeff's garages, inspection of his Healey which he is restoring, and looking over his extensive collection of Healey parts completed a very successful trip.

Saturday, December 12th was the annual Brandywine Region Christmas party at the home of Tom and Diane Zalewski in Elkton, Md. The spring like weather brought out a festive group: Diane, Tom, Elizabeth, and Mike Zalewski; Nigel and Jonathan Smart; Ann and Dave Ehret; Sue and Chuck Ott; Pete Roberts and Dee Caffrey; Jeff and Lisa Lanno; Jim Martin; John Montague; Joan and myself.

Dave Ehret brought along some of his own brewed Oktoberfest beer which was excellent and complimented the stock of fine British beer on hand. After appetizers, Diane had prepared a delicious festive dinner of Polish specialties: Galumpkis (stuffed cabbage), Pierogis (dumplings), and Latke (potato pancakes). Dessert was a "Viennese Cookie



Tom Zalewski 's1965 Austin Gipsy and 1965 Austin Healey BJ8.



Brandywine Group at our Christmas Party!

Table". This was an assortment of holiday cookies – some prepared by Diane and some by the invited guests. There was enough for everyone to take home a platter.

Tom and Mike had devised a Jeopardy type game consisting of question dealing with Donald Healey and the various Austin Healey models he produced. This was followed by a Christmas gift exchange. A good time was had by all! See the attached photo of the Brandywine group.

Mike had a surprise acquisition for the group to inspect. He purchased a 1965 Austin Gipsy over the summer. This is quite similar to the Range Rover that he had previously. It is rare to find one of these in the U.S., and is a very interesting vehicle. Moss Motors had an article describing the Austin Gipsy recently. See the attached photo of Mike's Gipsy and Tom's 1965 BJ8.

The Events Planning meeting will be held on Wednesday, January 13th, 2016. Location is Matilda's on route 896 in Newark, Delaware. There will be much to be discussed including our Encounter plans, so try and make it! 🇬🇧

**MOSS**

# MOTORING CHALLENGE

**AN EPIC SCAVENGER HUNT**

SIGN UP AT [MOSSMOTORS.COM/2014CHALLENGE](http://MOSSMOTORS.COM/2014CHALLENGE)  
**& GET YOUR CLUB INVOLVED!**



# HARRISBURG REGION

By Fred Bennett

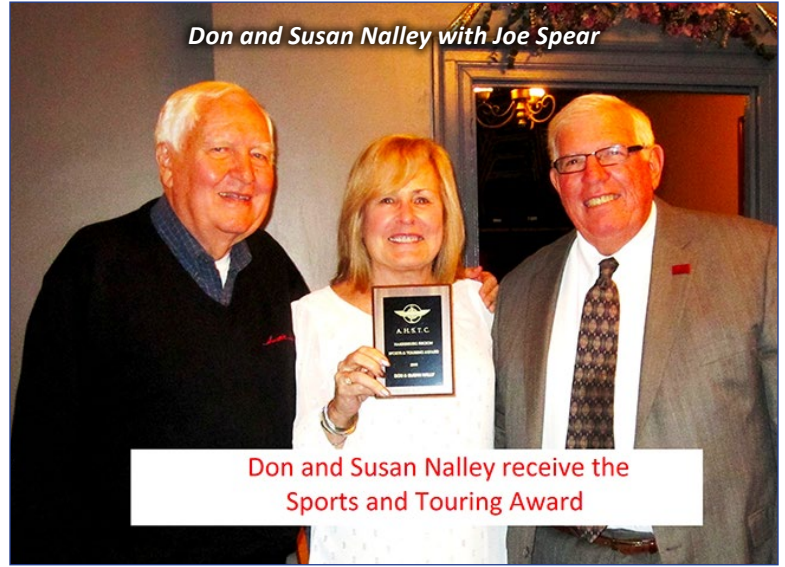
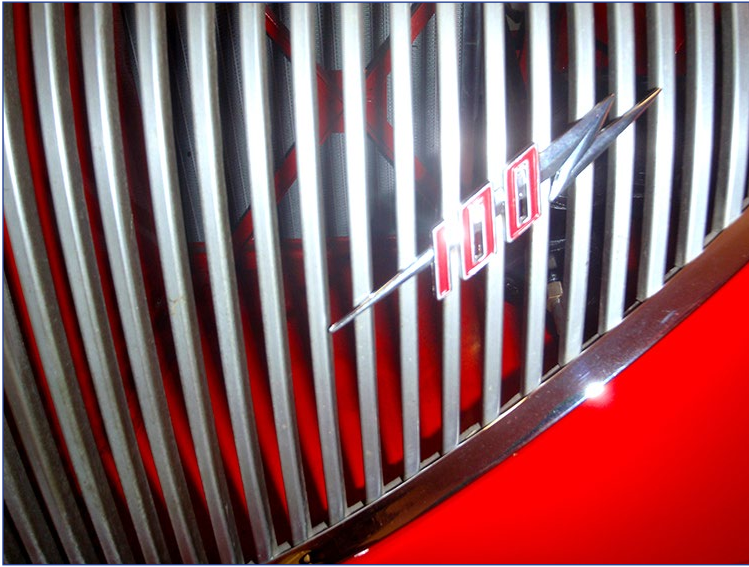

*Don and Susan Nalley with Joe Spear*

Don and Susan Nalley receive the Sports and Touring Award



*Donna and Fred Sherk accepting their Sprite award from Joe.*

Donna and Fred Sherk were awarded The Most for the Marques for the Sprite



*Joe presents the coveted Dick Waltz award to his wife, Barb Spear.*

O My!!! What a Studmeister



*Jim Cox proudly displays his new megaphone.*

Jim Cox Fully prepared for the Valve Cover Races



*That beautiful Healey instrument cluster.*



Can you spot the performance upgrades?

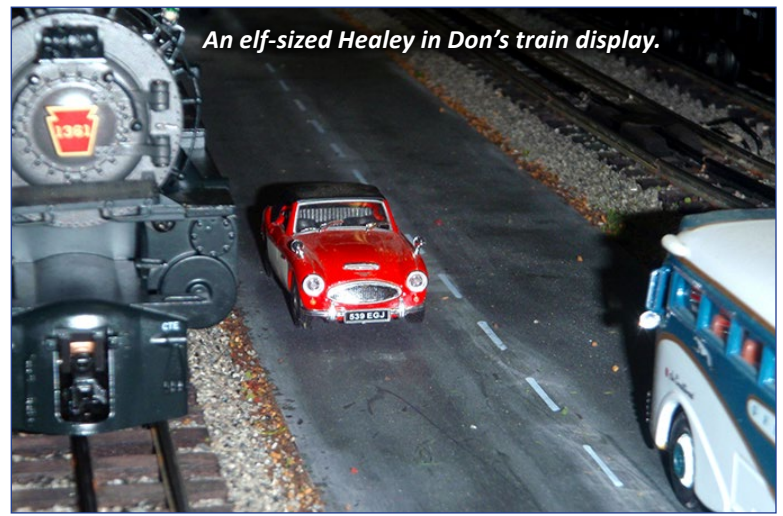

An elf-sized Healey in Don's train display.



Pip Pip! Cheerio! Don "gets his twit on!"



GENUINE



SPARES

**ZENITH**

"Parts for the Solution"

BRITISH SUPERIOR

Replacement Parts For S.U. & Zenith Carburetors

**JOE CURTO INC.**

Specializing in S.U. & Zenith-Stromberg Carburetors, British Car Parts and Repair

22-09 126th St.  
College Point, NY 11356

718-762-SUSU (762-7878)  
FAX: 718-762-6287

www.joecurto.com



**K&T VINTAGE**

SPORTS CARS LLC

1511 E. Woodlawn St. Allentown, Pa.

"The mount, shave and balance job you did on the new tires provided the smoothest driving I've experienced in 40 years!"

**Wire wheel and tire truing**

For a smoother ride



**VICTORIA BRITISH LTD**

IT'S NO FUN IF IT DOESN'T RUN

FREE Parts & Accessories Catalogs for:

**100-4, 100-6, 3000, Sprite**

VictoriaBritish.com | "KEEP 'EM ON THE ROAD" | 1-800-255-0088

BRITISH MOTOR HERITAGE APPROVED

MG

SUNBEAM

©2013 Long Motor Corp.

National Award-Winning

**Restorations & Repairs**

SPECIALIZING IN HEALEYS & OTHER BRITISH



Ken Beck, Owner

www.ktvintagecars.com 484-664-2353



# Long Island REGION

The MG Club Fall Foliage Tour was held on Sunday, November 1st. The weather was warmer than last year but no sunnier. I drove my Midget to the Cold Spring Harbor RR Station (which is somewhat removed from Cold Spring Harbor) and found it so much easier to drive than its big brother. It's been two years since I drove it so I had forgotten that. Those in attendance were Chris Aries, Lenny Berkowitz and Seth, James Burger and family, Scott Greenfield, Nick Nabavian, and myself. Chris Aries and Lenny Berkowitz drove the event. I didn't drive the tour as getting to the assembly place and back home would be enough for me. I regret not being able to go the distance as it is a great event, especially so if the weather is sunny and warm. Nick and I left for home together. I lost track of the Burgers and Scott. See the photo of Scott's Institute of Advanced Motorists badge.



*John Sprinzel, Ann Wisdom Riley, Peter Riley*

There have been some recent losses to the actual Healey family, and to our AHSTC Healey family: Margot Healey, widow of Donald's son Geoffrey, and Ann Wisdom Riley of Healey Rally fame, and our own John Morrison. I never had the pleasure of meeting Margot or Geoffrey, but I did meet Ann Riley at the 2009 Conclave in Kingston, Ontario. She and her husband, Peter Riley (along with John Sprinzel) were ever so accommodating, answering questions and signing autographs (including on my trunk lid). Ann's stories of her exploits as Pat Moss' co-driver and navigator were riveting.



*Institute of Advanced Motorists*

Now to John Morrison, what can I say about John? First, I personally will miss him, his good humor, and wry sense of the world. I got to know him well when he became corporate president, and I always looked for him upon arriving at Encounter. He wouldn't admit it but he was an untiring volunteer, someone you could always count on. As his health and mine became an issue, we became our own little support group. I know he was a great help to me.

God bless you John, I will miss you. 🇬🇧



*A rush to photograph and drive off.*



**H**alf a dozen members gathered at The Chimney Rock Inn in Gillette at 7:00pm on November 10th, 2015 for North Jersey's monthly club meeting. Attending were: Steve Feld, Steve Jekogian, Ernie Marateo, Jim Vollmuth, Ian Kessen, and George Crombie. Topics of conversation were many and varied, focusing on the upcoming Holiday Party (January 9th); the Red Mill Car Show (June 5th); the great time had by attendees to Enclave in Gettysburg; the up-coming Encounter in Delaware; Fall Fest, coming up in the fall (of course!); results of the mini tech session held at Ernie's in-laws'; accidents; and who knows what else? The call has gone out for club help regarding the staging, parking attendants, and ballot counters for both the Red Mill Show in Clinton, and Fall Fest in Summit; if you can lend a hand, please step right up and volunteer!

A few weeks ago, several North Jersey members met up at Shop Rite In Morristown for a morning of Cars and Croissants (and coffee and camaraderie!). Ian Kessen (BT7), Steve Feld (BT7), Steve Jekogian (BJ8), Ralph Scarfogliero (MGA Nasty-Boy with Jag V-12 power!), Bill Smith (TR6), and George Crombie (AN9 Sprite) were among those that showed up to kick tires. Around 10:30 or so, as the crowd was beginning to disperse, a few of the more hardy folks sallied off on an impromptu tour, while those remaining headed on home to attend to other, more mundane, chores like mowing the lawn or painting the mailbox or... Some of the more interesting vehicles on hand included a Stanley Steamer that was over a hundred years old, eight or nine Ferraris, two or three Teslas, a Cobra, and an old Bentley roadster.

The potential is there for all to read these words before the annual Holiday Party; however, you all should have received your E-Vites and made your reservations to attend long before now; if you haven't yet reserved, **NOW'S THE TIME** to RSVP and join us for a great evening with great people!

Stay tuned for more news and info regarding what's happening in and around the Northern (and central!) New Jersey area! 

# North Jersey

By George Crombie

# Lehigh Valley

Photos provided by Bob Snyder

It has been relatively quiet with the Lehigh Valley region; however, we did have a fantastic covered bridge tour and holiday dinner on December 5th at Morgan's restaurant in Allentown. The covered bridge tour was organized by Bob and Sue Snyder and a brace of Colorado Red BJ7's meandered for approximately 22 miles around the beautiful Lehigh Valley countryside crossing five of the seven covered bridges in the Lehigh Valley built between 1841 and 1882. The Beck's (BJ7 with tan top) and Snyder's (BJ7 with black top) enjoyed great weather with a very comfortable 55 degrees ... a real treat for driving during this time of the year. The tour ended at Morgan's restaurant where great fellowship and an excellent meal were enjoyed by fourteen LV members. It was great to socialize and catch-up with everyone as time slips by too quickly. Attendees included Bob and Judy Weaver, Bob and Mary Pritchett, Rick and Sue Brodeur, Phil and Jane Nase, Ken and Cindy Beck, Gerry and EJ Kunkle and Bob and Sue Snyder. Gerry Kunkle reviewed some new ideas for events for the upcoming driving season that we will continue to refine and discuss at future meetings. We are hoping for a rejuvenated and exciting upcoming driving season and we need your participation to make it successful!

After dinner, the group enjoyed an evening tour across the Wehr's Mill covered bridge, which is decorated with beautiful white lights for the holiday season. When you first see this covered bridge lit-up, it is quite impressive as

the Township spared no expense on the amount of lights they installed!

The Lehigh Valley also had new officer elections, with the following results: Ken Beck, President, Bob Pritchett, Treasurer and Secretary, Gerry Kunkle, Events Coordinator, and Bob Snyder, LV Newsletter Editor.

Not much else is going on with my Healey ('63 BJ7), which is running great, other than I installed a spin-on oil filter adapter which was a very worthwhile addition. Changing oil is a snap, much less messy, and it offers the benefit of a quality modern K&N oil filter. I did have a surprise around the end of October after coming back from a ride. The ride was great and nothing unusual except the next morning my left front tire had gone flat! After removing the tire, it was obvious



AHSTC dinner.





*Ken and Cindy Beck*

what had happened ... a large screw had found my tire. Luckily the tire held enough air while driving and Ken Beck made quick work repairing the tire and balanced/ tire shaved it back to perfection. I had purchased Michelin XAS tires a few years ago and K&T Vintage Sports Cars mounted the tires and balanced/tire shaved them for me. This process is really fantastic for delivering a smooth, shimmy free ride! The car drives very solid and smooth at all speeds (anyway, speeds that I am willing to drive!). There is no vibration or shimmy from improperly balanced or out-of-round wheels or tires. It is a worthwhile investment for enjoyable driving.

The LV Region is taking a break from regular Club meetings in January and February during these "frigid" winter months, but we will be back on schedule with a March meeting. Please look for an email announcement from Ken Beck regarding the next meeting date. 🇬🇧

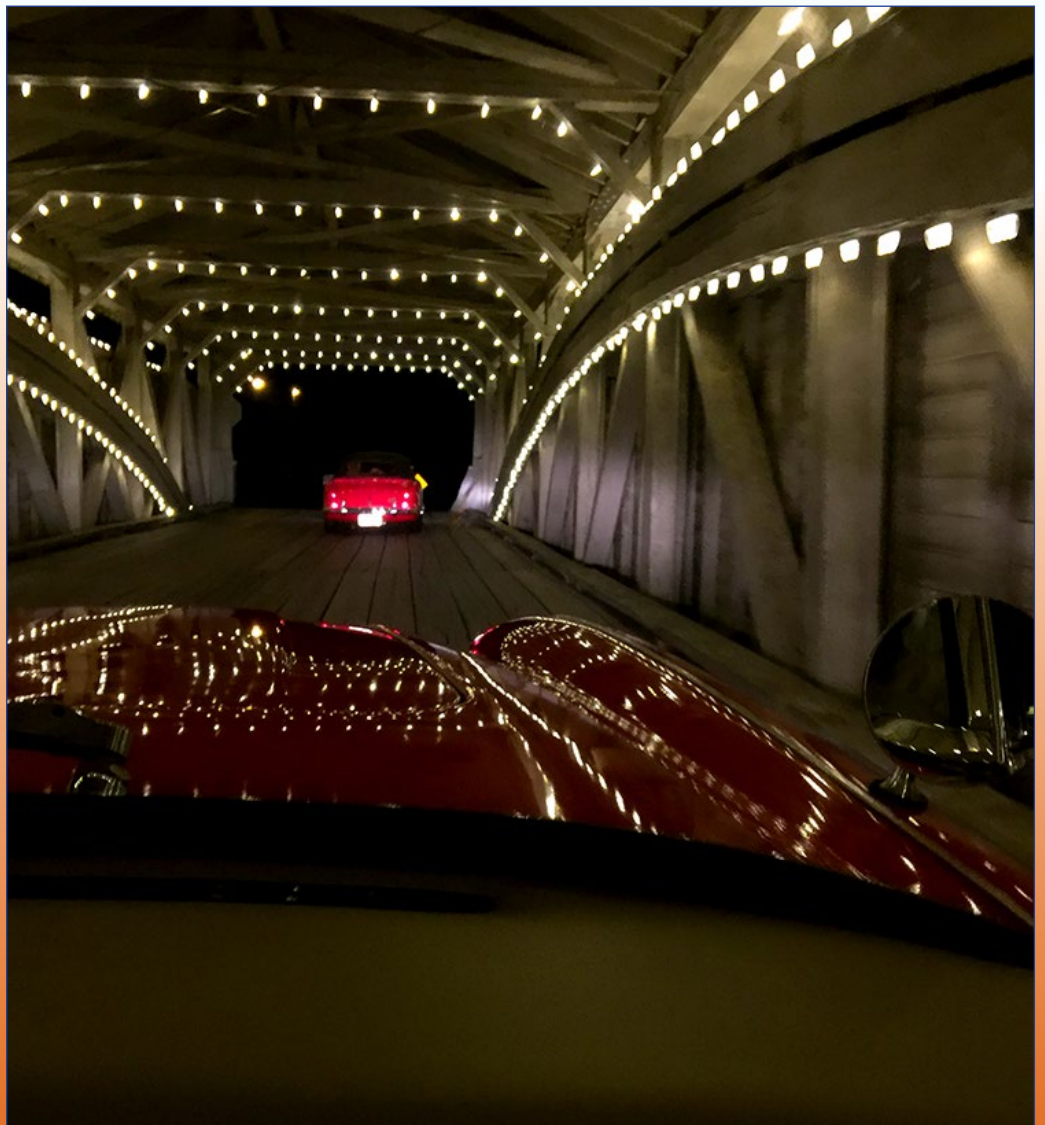



# HISTORY OF THE CLUB

## THE FIRST EIGHT YEARS

**D**uring September 1984, the Austin Healey Sports and Touring Club (AHSTC) celebrated its eighth anniversary. The club has grown from a group of five meeting in Harrisburg in 1976 to an average membership of over 700. Some of the faces involved with the club have changed, some have gone away and returned and others have stuck around; all of them helped bring the club to fruition as the friendly and sometimes gregarious organization that now exists. The most noteworthy single event of AHSTC is its yearly **ENCOUNTER** which is viewed by both our members and others as a well run gathering; drawing people from as far away as Ohio, South Caroline and Connecticut. In just a few years, AHSTC has made some significant contributions to the quality of the events available for all Austin Healey owners and aficionados. Regalia stores, flea markets, and photo and model contests were not regularly included as part of club events prior to be introduced by AHSTC at one of the **ENCOUNTERS**.

Thanks to Joan Null, Mike Haran, Jane Helgesen, Trish Woglom and Del Border for taking the time to edit the draft of this history and provide some missing information in addition to correcting my spelling. I also want to thank George Null for the use of his archive of newsletters as reference material. Special thanks goes to John Morrison for starting the club and holding it by the hand as Harrisburg President, Newsletter Editor and Corporate President for the first few years.

AHSTC had a tentative beginning with a group of five enthusiasts getting together at the home of Larry Verdekal in Camp Hill, Pa in September of 1976. Larry Verdekal set up the initial meeting by the simple expedient of stuffing his business card under the wiper blade of any Healey that he saw and organizing the gathering at his place. The Austin Healey Club of American and the Austin Healey Club, Pacific Centre existed but did not have events that could be regularly attended by people in these Northeast states. A monthly newsletter was initiated almost immediately as a means of tying the various people together and promoting new memberships through complimentary copies to interested parties. The newsletter consisted of a few typewritten, corner-stapled Xeroxed pages, consisting of "last meeting" and "next meeting" notes. By the end

## ARTICLE | *History of the Club*

of 1976, John Morrison was the President of AHSTC (the club name was official at this point, proposed by Jeb Boyd), the club was meeting once a month at the Morrison residence, dues had been established and a preliminary set of bylaws had been written.

In March 1977, the club (comprised mainly of Harrisburg and York residents) was meeting at Dante's Restaurant and had officially approved the bylaws. Those bylaws defined the structure of the club, set up provisions for memberships, an annual participation award and set the club goal as one of preserving the Austin Healey marque. There was some discussion as to whether the club should be for the "big" Healeys alone but that idea was quickly overruled by a sense of commonality and comradeship for the Sprite owners who shared their admiration for the Austin Healey name. About this same point in time, the need for an official Parts Manager was identified and Jeb Boyd was volunteered for the position. April 1977 saw the first "official" club event, consisting of a driving tour of about 55 miles from Harrisburg to the Hunt Valley Inn in Maryland. The "Hunt Valley Inn Tour" became the "Hunt Valley Inn Attempt", after inclement weather and mechanical issues forced a midway reversal in course.

Unbeknownst to those involved in AHSTC, another group of Healey owners was getting together in the Wilkes-Barre area of Pennsylvania during the latter part of 1976. That group had similar ideas in mind and called themselves the "Tri-State Austin Healey Club" since they planned a "regionalized" club servicing Pennsylvania, Jersey and New York, AHSTC was likewise unknown to Mike Delevan, the force behind this new group. Mike and Ron Seferyn had talked about a club and actually got started with the help of George Null and Joan Null whom they contacted as the result of their mutual attendance of the "Healey East" meet at Cherry Hill, New Jersey in the summer of 1976. George and Joan, along with Mike, Don Olsen, Roger Ninotti, Lee Guth and a few others met in the fall of 1976 to kick off the club. At this point, the Nulls were traveling from York and were not aware that they lived right around the corner from the fledgling AHSTC. By the end of 1976, the Nulls had discovered Morrison and AHSTC; John Morrison and Mike Delevan soon began to exchange correspondence. Both groups seem to have gotten inspiration from that Cherry Hill meet of Pacific Centre's where the attendees saw Donald Healey, Fred Horner (then VP of British Leyland America) and Mike Dale (President of British Leyland).

June of 1977 saw the Tri-State club and its 35 or so members became a second "Region" of AHSTC which forced some major changes to the bylaws which did not then account for any group beyond Harrisburg. The region concept was adopted and Wilkes-Barre joined Harrisburg on the masthead with Mike Delevan as the region president. Wilkes-Barre continued to meet at Delevan's house. The newsletter, which had been a handy vehicle for information, also received a format change to include regional new inputs well as some standard columns like "Healey at Large".

July saw a change in the Harrisburg meeting place to the Knights of Columbus Hall in Camp Hill where it remained for an extended period of time. Also in July, the second tour event of 1977, to the Bavarian Summer Festival in Barnesville, PA was undertaken. The was renamed to "The Teutonic Torture Tour", due to the high temperatures, slow-moving traffic on rural roads, and consequent over-heated Healey cooling systems.

## PART 2

The first anniversary of AHSTC passed with some significant changes in the club. A new region was formed in the Philadelphia area by John Morrison's brother Pete; meeting at Ye Old Beef'n'Ale in Fort Washington. Don Hoffer was busy working on an Austin Healey Repair Manual to supplement the published information with the experience

### **AT THE CLOSE OF 1977, CLUB OFFICERS WERE AS FOLLOWS:**

**HARRISBURG:**  
**PRESIDENT: JOHN MORRISON**  
**SECRETARY-TREAS: BARBARA BOYD**

**WILKES-BARRE**  
**MILE DELEVAN**  
**RON SEFERYN**

**PHILADELPHIA**  
**PETE MORRISON**  
**ROB MORROW**

**PARTS MANAGER: JEB BOYD**  
**MEMBERS COORD: DON OLSEN**  
**EVENTS COORDIN : GEORGE NULL**  
**NEWS LTR EDITOR: DON HOFFER**



## ARTICLE | History of the Club

of the home mechanic. There were now 21 paid members of AHSTC and another 27 individuals getting complimentary newsletters but procrastinating on the dues. An outing was organized in September by Hoffer and consisted of a camping trip to Avalon, New Jersey. As the club grew, the workload of the organizers had increased and offices for an official Newsletter Editor as well as Events and Membership Coordinators were defined in September. Some members of AHSTC attended the Pacific Centre sponsored gathering in New Market, Virginia. They saw the car show and watched Donald Healey present awards from a fire escape with bullhorn in hand so he could be heard. By the end of 1977, there was talk of putting on the car show to top all car shows on the East Coast and the idea for an **ENCOUNTER** was born.

AHSTC continued to expand its horizons in 1978 and grew in membership to 74 by May. Don Olsen staged the first of a series of Healey retrievals in February with number two following shortly thereafter. That same month, the first official membership cards were issued.

Although not listed as such by Mr. Webster, retrieval is a noun which is “a collection of individuals working as a unit to claim an Austin Healey from the scrap yard operators and the ravages of rust.” Many, but not all, of the retrievals made over the years were recorded in minute detail by our overzealous editors and reported in the newsletter. Some of the cars were actually in the “as advertised” condition which some were not; but they all had a good story attached to them.

George Greenwood became the first Philadelphia region Parts Manager in March. Under the care of Joan Null as Chairman, **ENCOUNTER '78** became a reality in the summer, showed a whopping profit of \$2,250 and was deemed to be an annual event of AHSTC. The name for the event was proposed by John Morrison, inspired by both the “encounter group” concept of psychology and the movie “Close Encounters of the Third Kind” released in November 1977. Events proceeded rapidly at the end of the year; Wilmington and North Jersey regions were added with Bill Oberholtzer and Wayne Wirta as the respective presidents. Philadelphia changed its meeting place to the American Legion Post in Willow Grove where it remains to this day. Don Hoffer spearheaded Retrieval Number 3 and a decision was made to have a contest to pick an official logo for the club. November saw a major change in newsletter production, with the acquisition of a mimeograph machine by the club. This was the direct result of membership growth and the consequent difficulty in surreptitiously producing the newsletter on company time using the company Xerox. Thus was the infamous “Ol’ Yeller” born. In December, the club got its present Post Office box in York, PA. It was toward the end of 1978 that Pete Morrison challenged the other regions of AHSTC to a Philadelphia Invitational Teamkane event – and as is usually the case, the host lost.

Paul Helgesen headed the fourth Healey retrieval of record in January, 1979. Thanks to the artistic talents of Bob Pense, the club had a logo (same as the one used now) on its letterhead and newsletter by March. March also saw the first annual Rat Factory Rallye staged by Doug Reid in Maryland. During the early part of 1979, we had also made some contract with the Austin Healey Club Pacific Centre and they agreed to help fund **ENCOUNTER '79** which was by then in the planning stages in Harrisburg. By May, Mike Haran in New York was making serious progress on a Long Island region of the club. Sure enough, George and Joan were there to lend a hand and kibitz.

John Morrison hosted Retrieval #5 in June, 1979 just prior to **ENCOUNTER**. In July, we were invited by the Sports Car Club of York to co-sponsor a Young Handicapped Peoples Rallye. AHSTC had helped in the event in 1977 by taking a number of handicapped youths along as navigators on a rallye. We couldn't help in 1978 because the membership was pretty well engrossed in putting

### Austin-Healey

100-4-6-3000 -Sprite

**SHOCK ABSORBERS:** Each

FRONT BIG HEALEY.....	\$102.00
FRONT SPRITE.....	\$102.00
REAR (All models).....	\$75.00
HEAVY DUTY UPGRADE.....	\$10.00
SHOCK LINK (New or Rebuilt).....	\$call

**BRAKES:** sleeved and rebuilt ..

Big Healey Master 100-4, 6, 3000.....	\$95-\$195.00
Big Healey Booster Servo.....	\$445.00
Big Healey Caliper.....	\$115-\$145.00
Sprite Master 1957-66 Twin.....	\$225.00
Sprite Master 1967-79.....	\$125.00
Sprite Caliper.....	\$85.00
Cylinders sleeved only, brass or SS.....	\$50-\$95
Kingpin swivel axle rebushed.....	\$60-\$95
Front end A-arm (Sprite).....	\$95.00

**CARBURETORS: COMPLETE REBUILDING**  
Disassembly, cleaning, bodies rebushed, new std. size throttle shafts, jets, needles, float valves, gaskets. FLOW BENCH TEST.....\$375-\$445/pair

**CARB BODIES REBUSHED**  
and new throttle shafts.....\$85 each

Prices shown are for Exchange or Yours Rebuilt.  
Core charges apply if items are ordered prior to  
(and are refunded after) our receiving old units.  
Free catalog. [www.applehydraulics.com](http://www.applehydraulics.com)

**APPLE HYDRAULICS**  
1610 Middle Road, Calverton, NY 11933  
631-369-9515, FAX: 631-369-9516  
Toll Free 800-882-7753  
VISA, MC, DISCOVER, PAYPAL, COD

oct08

together **ENCOUNTER '78** which occurred at the same time. It was in July that Bill Murtha of Philadelphia received the T.B.B. Award (Tacky Beyond Belief) for his display of purple spark plug wires at British Car Day in Bowie, MD.

**ENCOUNTER '79** was held at the Penn Harris Motor Inn at Camp Hill, Pa. Geoffrey and Margot Healey along with their daughters, Kate and Cecil, were in attendance for the event thanks to the support of the Austin Healey Club, Pacific Centre who footed the transportation bill as part of their meet on the West Coast. Keith Rochelle of Pacific Centre showed up to see how we were spending their monies and seemed pleased with the results. The Capital Area region of AHCA also helped by supplying able bodies to work registration during the event as well as helping organize the show. Las Vegas Night was added to the agenda for something to do on the first night of the event while registrations wandered in. That same month saw the introduction of the "Mr. Finespanner" column in the newsletter (which was a community effort by members of AHSTC and AHCA, Capitol Area) and a change in the name of the Wilmington region to Brandywine as it is now known. "Mr. Finespanner" contributed a wealth of supplemental information on the nuances of Healey repairs. During the three or four years while it was a semi-regular column, "Mr. Finespanner" provided information on subjects ranging from oil and filters to complete engine rebuilds.

## PART 3

The closing months of 1979 saw more changes in the club. The membership roster stood as 280 and we lost the services of our newsletter editor of the previous two years as the Hoffers left for Indonesia. The Wilkes-Barre region changed its name to Lehigh Valley and got a new president by the name of Lee Guth. As a final note for the new year, the club decided it must request a dues increase of \$6.50 after holding the line at \$5.00 for two years.

The new year (1980) brought with it a new region in Maryland called Potomac with Doug Reid as President, meeting at Bruce and Inan Phillip's residence. John F. X. Fenerty assumed the Presidency of the Philadelphia region as did Chris Haislett at Brandywine. Lehigh Valley changed their meeting place to the Mansard Inn in Catasauqua, PA. About June of that year, Don Hoffer reappeared in the newsletter as "Our Man in Jakarta" and sent some pictures taken of the Healeys (people) during a side trip to England. John Morrison had to step down as the Harrisburg



### Healey Surgeons

7211 Carroll Avenue  
Takoma Park, Maryland 20912

(301) 270 8811

E mail: [enquiries@healeysurgeons.com](mailto:enquiries@healeysurgeons.com)

come visit us on our website:  
[healeysurgeons.com](http://healeysurgeons.com)  
for tech tips, tech chats,  
download price list, check on current prices  
and on line ordering

Parts • Service  
Restoration for 100-4 to 3000 Mark III

Bruce and Inan Phillips

President due to work schedules and the job was assumed by the VP Dave Bayne. Harrisburg changed their meeting place to the Timberlodge Tavern and the first annual All-Region Picnic was hosted by Philadelphia.

In addition to other changes, the club's accounting methods were modified to keep separate ledgers for the regions and set up an operating fund for the yearly **ENCOUNTER**. These changes made solvency a little easier to monitor and reduced the frustration of the treasurer.

**ENCOUNTER '80** was again held at the Penn Harris Motor Inn and sported a bright new idea, thanks to Jane Helgesen and Dave Bayne, called a RegaliaStore. It seems that Dave told Jane that part of her job as Treasurer was to think of ways for the club to make money (prior to the elections, he said that the job was simply to keep track of the club funds). Anyway, the resultant brainstorming session came up with the store idea and everyone thought it was a great one that had not been tried. This was the year that the Austin Healey Cookbook was published by Joan Null and the first time that **ENCOUNTER** was set to cover a four day period so the events could be spread out a little. The Philadelphia Invitational Teamkana was made a standard event call the Teamkana complete with a huge traveling trophy for the winning regions. Del Border and his "stock" 3000 immediately

## ARTICLE | History of the Club

installed the trophy on the Harrisburg mantle that year and succeeded in keeping it there until 1984.

Since the early part of the year, negotiations had been in the process with AHCA to hold a joint event. George Null attended the AHCA Conclave in Toronto to help present the proposal with a date of mid-1981 and a tentative site in Fredericksburg, VA. At the same time, there were louder rumblings of a jointly sponsored national meet in 1982 coincident with the 30th anniversary of the Austin Healey. The start of this idea seems to have been back in 1979 (at **ENCOUNTER**) with Geoff Healey, Keith Rochelle, the Nulls and the Morrisons.

Retrievals numbered 6 and 7 occurred in June and July of 1980 with #7 being sponsored by George Null. August brought with it a separate Austin Healey class of the famed New Hope Auto Show thanks to the persistent efforts of Joan Null.

AHSTC became a Pennsylvania non-profit corporation in the summer of 1980 with the passage of the bylaws and paperwork submitted by John F. X. Fenerty. As required of a corporation, a Board of Directors was elected. Each of the region presidents automatically becomes a member of the Board per the bylaws.

September saw an end of the season clambake at the Jersey shore sponsored by the Philadelphia region with Paul and Trish Woglom pulling it all together. The Board of Directors gave official approval for **Conclave-Encounter** as a joint meet with AHCA Capitol Area prior to the end of the year.

January 1981 arrived with the results of both the regional and corporate elections for officers. Corporate officers were John Morrison (President), John F. X. Fenerty (Secretary), Jane Helgesen (Treasurer), and George Null (Newsletter Editor). The Presidents of the various regions were Dave Bayne (Harrisburg), Bob Miller (Lehigh Valley), John Fenerty (Philadelphia), Dave Ehret (Brandywine), Ben Cohen (North Jersey), Mike Haran (Long Island), and Doug Reid (Potomac).

Harrisburg began a long series of winery tours this year. By April, there were solid plans to have an International Meet in 1982 and questionnaires were published to get inputs from the membership as to what type of events were desired. The Third Annual Rat Factory Rallye was hosted by Doug Reid and Don Olsen pulled off Retrieval #8. Lehigh Valley put on the All Region Picnic in June with a great turnout by all of the regions.

**Conclave-Encounter** in July was deemed a grand success with over 500 registrations and 390 cars on display. There would have been more registrations but we ran out of registration packs on Saturday and the people kept coming in to see what was happening. The event was made

even more memorable for some since it was also the first time that many of the attendees had seen Donald Healey in person. Other notables were Gerry Coker, a former Healey works man, and Louise King who owned the first Austin Healey in the United States. At the Board of Directors meeting, complete support of the proposed International Meet in Snowmass, Colorado was expressed and decision was made to proceed with **ENCOUNTER '82**, but in a low profile. The Board felt that there had to be a show for those not planning on attending Snowmass but did not want to promote it as an alternative thereby stealing attendance. The Philadelphia region was given approval to host the **'82 ENCOUNTER** which broke with tradition. Harrisburg, with Joan Null as Chairman, had been doing an outstanding job for four years but Philadelphia wanted to take a crack at it.

## PART 4

August and September were active months for the club with the New Hope Auto Show and John Zimmer taking on the task of supplying judges and the Wogloms setting up the 2nd Annual Clambake. The August newsletter looked a little strange since 3/8 of an inch was trimmed off one edge. It seems that the postmaster weighed a copy to check the postage and found it

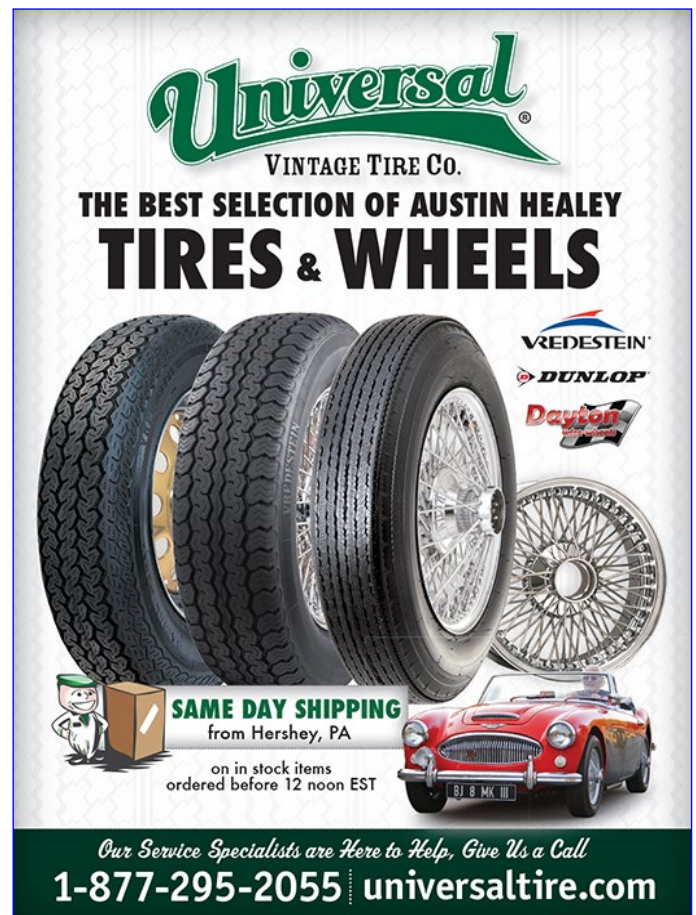

**Universal**  
VINTAGE TIRE CO.  
THE BEST SELECTION OF AUSTIN HEALEY  
**TIRES & WHEELS**

VEDESTEIN  
DUNLOP  
Dayton

**SAME DAY SHIPPING**  
from Hershey, PA  
on in stock items  
ordered before 12 noon EST

Our Service Specialists are Here to Help, Give Us a Call  
**1-877-295-2055** [universaltire.com](http://universaltire.com)

to be too heavy for the stamp used. Our quick thinking and harried editor did not want to lick another 380 stamps since he was already late leaving for **Conclave-Encounter** so out came the paper cutter.

Demands on Jane Helgesen's time by her employer forced her to turn over the duties of Treasurer to Sue Morrison in September; a couple of months early for Sue's elected term in '82. In November 1981, a brand new region entered the ranks and called itself Pittsburgh with Karen and Gene Kline as their founding members.

The results of the regional and corporate elections for officers provided some new names for tenure during 1982. Corporate officers were John Morrison (President), Nina Null (Secretary), Priscilla Hooper (Treasurer) and Bill Bates (Newsletter Editor). The Presidents of the various regions were George Null (Harrisburg), Marv Gordon (Lehigh Valley), Paul Woglom (Philadelphia), Dave Ehret (Brandywine), Ben Cohen (North Jersey), Mike Haran (Long Island) and Gene and Karen Kline (Pittsburgh). Alas, 1982 also heralded the demise of the Potomac region. The people were still members but were too dispersed to maintain any regularity in meetings or events.

1982 brought with it some concern by the corporate leaders for the direction in which the club was headed. A questionnaire was published in the newsletter which asked the members to indicate what they wanted out of the club, what they liked and what they disliked. The intent was to improve the overall benefit to the membership by offering more of what they really wanted. The results of the survey indicated that there was a great desire to additional technical information. Subsequent to the survey, tech articles began to appear on a more regular basis.

Philadelphia was hard at work preparing for the **ENCOUNTER** they were hosting in August. Technology caught up with the Philadelphia region in February when Bob Ianelli and Jeff Smith presented a slide show tech session on tune-ups. They had gone through a complete tune-up on Bob's care and photographed the entire session to show at the monthly meeting. Del Border sent out a challenge to the other regions to have a gymkana at the York Fair in May. Everyone had been trying to beat Harrisburg at the Teamkana events and they wanted to see if there were really and serious challengers.

North Jersey agreed to sponsor the All-Region Picnic to be held in June. Doug Reid did another great job with the fourth annual Rat Factory Rallye at the end of April.

The International Meet was shaping up to be quite an event based on the reports at the beginning of June. There was a lot of information appearing in the various club newsletters about the International Meet, including an article on tuning the Healey for operation at the high (4-6000 foot) altitudes that would be found in Colorado. There were 335 registrations with people from Guam, New Zealand, England, Australia, Germany, Austria and Canada. There were even tentative plans for the English to bring some their cars. Over 200 people were signed up for the "Rallye to the Rockies" which looked like a treasure hunt requiring participants to purchase a newspaper in each city they passed and then change a spark plug and a tire when they arrived.

Several members of AHSTC attended the meet in Snowmass, including the Hoffers, Pepes, Joan Null, the Morrisons and Paul Wronski, and agreed that they had never seen so many Healeys in one place before in any condition. They brought back some good stories and a lot of pictures. The people who went to Snowmass ran into Healeys in several states (even found one sightseeing at some hot springs in Yellowstone national Park) and discovered clubs in North Texas and Oregon whose members brought some fine examples of the cars. Joan submitted a detailed diary of her trip and the Rallye to the Rockies with Paul Wronski to the newsletter which was published in August. They were traveling with Healeys from Washington and Virginia and met members of other clubs along the route who offered assistance and otherwise treated them royally. The Morrisons had the dubious honor of setting up and running the Regalia Store at the event with a lot of help from the AHSTC contingent and a few others. The store was a huge success and made a serious contribution to the financial success of the week long event.

One by-product of the enthusiasm of the International Meet was a letter by Carolyn Thompson relative to initiating a North American Austin Healey Club. The subject had come up on several occasions in the past but there had never been such a concentrated forum in which to pursue the idea. Carolyn met with all the club representatives at Snowmass and then published an open letter in all the newsletters with a plea to the individual members. AHSTC Board discussed the subject and decided to get feedback from the membership and hold off on the issue until additional information was available from Carolyn and the other organizers.

Right on the heels of the International meet came **ENCOUNTER** hosted by Philadelphia and held in the historic

Valley Forge area. The overall event had a Philadelphia theme, which was a little different but still retained the cars at the center of attraction. Even though **ENCOUNTER** publicity was held to a minimum so as not to adversely affect the International Meet, the turnout was excellent with a good showing by all of the AHSTC and AHCA regions on the East Coast. In fact, AHCA members from South Carolina showed up en masse and practically walked away with all the car trophies. It was obvious, to the relief of the Harrisburg group, that other regions were capable of hosting an **ENCOUNTER** and North Jersey volunteered to co-host the 1984 event with Long Island.

1982 came to an end with a lot of activity within the club. John Morrison resigned as the Corporate President after six years in the office and was replaced by George Null. Harrisburg agreed to host the '83 **ENCOUNTER** in the Lancaster area. New officers for 1983 included region presidents Carol Hodgman (Long Island), Joe Pepe (Philadelphia), Steve Jekogian (North Jersey), Don Olsen (Harrisburg), Bobbie Jezerowski (Western PA), Bob Messinger (Lehigh Valley), Sean O'Neil (Brandywine) and corporate officers Bill Bates (Newsletter Editor), Joe Pepe (VP Membership), Mike Haran (Secretary), and Priscilla Hooper as Treasurer. Sometime during 1982, the Pittsburgh region began calling itself Western Pennsylvania which was a little more descriptive of the territory serviced.

Another change occurred at the end of '82 which affected all the membership – the responsibility for maintaining the membership roster which was assumed by Joe Pepe of Philadelphia. John Morrison had been doing that task along with several others but could not continue. In the changeover of the computers, an error was made and the entire list was almost lost. However, by March of 1993, the list was sorted out and the labels for the newsletter were being printed properly.

Philadelphia disappeared from the newsletter for two or three months in 1983 due to some confusion over who the editor really was. Armand Gersbach finally picked up the gauntlet and finished out the year for the region.

Pacific Centre's Membership list was raided to get additional names for the newsletter mailing list.

There was some degree of indignation over the fact that the "father" of the Austin-Healey was subjected to such an inappropriate venue. The 'banquet' was Colonel Sanders' take-out. Almost immediately, our members began talking about how much better a job could be done. Joan and George Null, veterans MG club gatherings, suggested that we as a club could do a first-class Healey Meet. Joan Null volunteered to chair the effort. **Encounter** was initially from a raffle for a piece of Pfalzgraff furniture, arranged by Paul Helgesen. Paul was also responsible for all the **Encounter** graphics designs, trophies, regalia and tee-shirts. Because of the uncertainty of the turnout for **Encounter**, it was decided to Not put dates on regalia items, for fear of ending up with a large inventory that couldn't be sold.

The newsletter continued in this mimeographed format through 1982 with continuing complaints from the membership regarding its' readability and durability, made worse from time to time by efforts to reduce production costs by reducing the type face size. This resulted in a popular movement to have a magnifying glass included in the newsletter mailing. Newsletter costs during this period consumed more than 50% of the membership fee, leaving little for other operating expenses and "regional rebates".

The Potomac region was formed by a number of people belonging to The Capitol Area Club of AHCA. There appeared to be several different motivations involved in the formation of this region. Some of those involved were genuinely upset with AHCA policies and personalities, while others felt that cross-membership was the best way to work towards a merger of all the North American Healey Clubs into a single entity. 🇬🇧

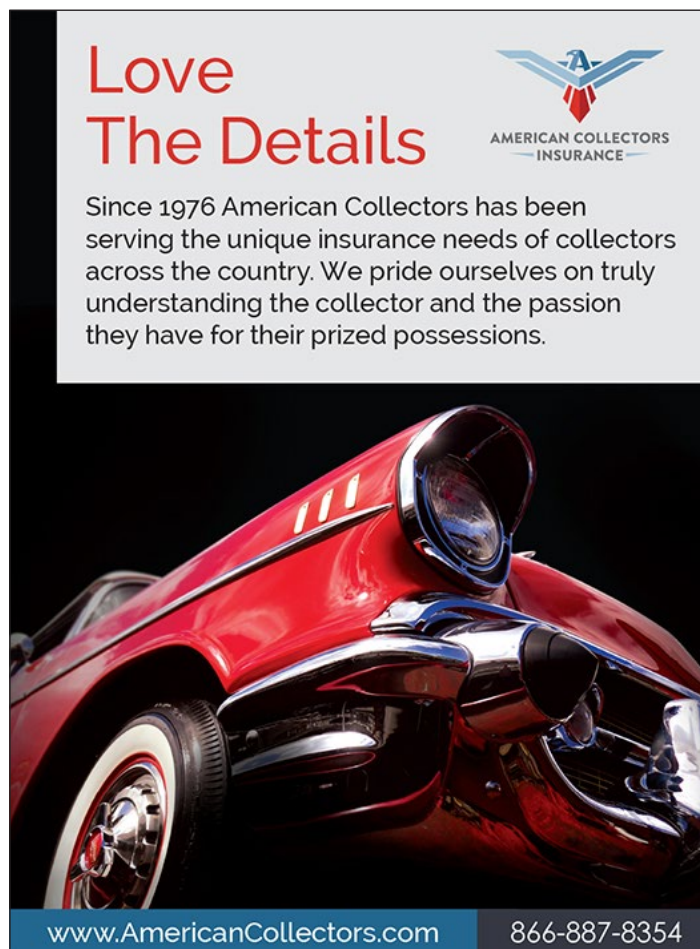

**Love  
The Details**

AMERICAN COLLECTORS  
INSURANCE

Since 1976 American Collectors has been serving the unique insurance needs of collectors across the country. We pride ourselves on truly understanding the collector and the passion they have for their prized possessions.

[www.AmericanCollectors.com](http://www.AmericanCollectors.com) 866-887-8354

# J.C. TAYLOR

## ANTIQUÉ INSURANCE

1-888-ANTIQUÉ

JCTAYLOR.COM



# MEMBERS CORNER

By Rick Brodeur

**O**ur member lists are available to any member just for the asking. Each Region President has a copy that can be distributed, and I can send out a copy to any member who requests one. My email address for the Club is [membership@austin-healey-stc.org](mailto:membership@austin-healey-stc.org). If you have any questions about your membership please contact me. Contacting me is the quickest way to solve a membership problem. My phone number and email address are on the inside front page of the Flash and also on the web site.

## WEBSITE INFORMATION

<http://www.austin-healey-stc.org>

If you haven't renewed your membership, your access to the website has been stopped.

**Please renew your membership now.**

As events are announced we are posting them to the website.

We'll soon be posting the events calendar for 2016.

If you haven't signed up you should so you can get access to member-only content.

When you sign up I'll get an email, within a day or two, I'll verify you're a member and authorize access to the member only area which includes past Flash newsletters.

When you log in to the site you will be at your 'Profile' page.

Here you can add information about yourself, change password, etc.

From there you go to the website by clicking on [The Austin Healey Sports & Touring Club](#) in the grey bar at the top of the page.



4 Tabas Lane  
Exton, PA 19341

We Do Custom Powder Coating

*from Suspension Brackets  
to a Complete Chassis*

*With In-House Sandblasting  
No Minimum Quantities  
And a Large Color Selection*

**If It's Metal  
We Can Coat It!**

Contact us at  
610-280-3770  
[sales@powdercraft.com](mailto:sales@powdercraft.com)  
or go to [www.powdercraft.com](http://www.powdercraft.com)  
for more information.



[www.BritishWiring.com](http://www.BritishWiring.com)

**BRITISH WIRING** 

Suppliers of Wiring Harnesses, Wire, Terminals & Sundries  
for British Classic Cars and Motorcycles

Toll Free: 866-461-9050  
Fax: 610-845-3518  
email: [BritishWiring@Ameritech.net](mailto:BritishWiring@Ameritech.net)

P.O. Box 185  
617 Walnut St.  
Bally, PA 19503

**BEHIND YOU ALL THE WAY!**



Trish & Paul Woglom  
801 West Eighth Street  
Lansdale, PA 19446

 **CALL US TODAY  
(800) 220-7913**

# ENCOUNTER 2016 – THE VENUE

Rick Brodeur

The Sheraton Wilmington South hotel is the setting for the Brandywine region's **Encounter 2015, which will be held August 10-13, 2016**. This is the first time that there has been an Encounter held at a hotel in Delaware. This hotel was completely renovated 3 years ago and is a fantastic venue. The entire 2nd floor that overlooks the huge lobby is being taken up by our group, with Hospitality, Regalia, Registration and tech sessions in close proximity to each other. The Brandywine group has plenty of events planned for the area.



Call for reservations. Here is the information: **Sheraton Wilmington South Hotel**  
**365 Airport Road**  
**New Castle, Delaware, 19720**  
**Phone: (302) 328-6200 for reservations.**  
**<http://www.sheratonwilmingtonsouth.com>**

Mention "Austin Healey Encounter" to get the special rate of \$119 plus taxes.  
Deadline for the room block hold: 10 July 16

The hotel is located right on I-95, just south of Wilmington, in New Castle, Delaware. You can see it from I-95. If you don't fancy taking the Healey on the interstate, try the back road route – from the north I like to take PA route 100 south to Delaware State Route 141, which goes right by the hotel. It is a twisty road through some rural areas.

The hotel has designated Healey parking in the large outdoor lot, and for a mere \$20 for the entire event, you can have indoor overnight parking for your Healey. The parking garage will be opened up for 1 hour in the evening and one hour in the morning for you to store and remove your car. If you need to go in or out at other times, you can make arrangements with the hotel staff. The staff can send someone down to check you into or out of the garage, which is underneath the hotel. There are only 45 spaces available, so send in your registration form early to make sure that you get a space. They are available to the first 45 to register and reserve a spot. I suggest that you book now to get your overnight parking space. The hotel has a complimentary shuttle that can be booked to take small groups to local attractions.

There are three classes of rooms that have been reserved for us. The traditional double room, which is a regular hotel room that you can have with one king bed or two double beds. The junior suite has a king bed, and also has a refrigerator and microwave. The Deluxe Suite has one king bed plus a pull-out couch. It also has an oversized bathroom with Jacuzzi tub and separate stall shower, and many provide a dining table for four. If you are bringing the family, you can combine a Deluxe Suite with a traditional double room for a 2-bedroom suite experience. Complimentary wifi is provided in all of the hotel rooms.

**GET THIS – ALL OF THE ROOMS ARE THE SAME PRICE!** That's right, just \$119 per night for any of the rooms or suites. They are available on a first-come, first served basis. I suggest that you book now to get your choice of room.





*Traditional double room*



*Junior King Suite*

Here are the websites for some local attractions, in case you are interested in extending your stay and seeing many of the fine things that Delaware has to offer:

- Old New Castle <http://www.newcastlehistory.org/houses/education.html>
- Delaware Park Casino <http://www.delawarepark.com/>
- IMAX Theater <http://www.penncinema.com/>
- White Clay Creek Park <http://www.destateparks.com/park/white-clay-creek/>
- Hagley Museum <http://www.hagley.org/>
- Winterthur Museum <http://www.winterthur.org/>
- Brandywine Creek <http://www.destateparks.com/park/brandywine-creek/>
- Delaware Museum of Natural History <http://www.delmnh.org/>
- Wilmington and Western Railroad <http://www.wvrr.com/default.aspx>
- DuPont Mansion <http://www.nemoursmansion.org/>



*Deluxe King Suite*



THE FLASH

# ENCOUNTER YESTERDAY & TODAY

Article by Loe Kob



Gettysburg 2015

Photo by Chaz de Bourbon

**W**hile our Encounter Committee was busily completing its laundry list for all the upcoming events, talk shifted into a nostalgic gear.

In the earliest years – more than a dozen guys would park step-vans, long enclosed trailers, etc. offering enough parts adjacent to the popular show field to build several copies of just about any Healey model. It took most of an afternoon to pick through the piles and cut deals, perhaps for a complete rolling chassis.....not many vendor 800 numbers to dial offering overnight delivery back then.

While sifting through the small collection of remaining old club stuff in our basement not ruined by Hurricane Floyd a few months ago, I came across a couple of AHSTC newsletters from about the time the (as yet unnamed) concept of Encounter was formulated. There were only a few dozen members then, the newsletter was hand-typed on yellowish elementary-school tablet quality paper (rag?), and all mailing addresses were hand-written/stamped. I think the copies were run on a hand-cranked 'mimeograph' machine.

That was the mid-seventies. Our club grew in size, became regionalized. Encounters drew some wild characters. The most memorable to me were a few Canadians who would arrive with a keg in the back (sometimes a trailer??) of their LBC's – didn't have to go inside for the Hospitality suite when they appeared. We were graced by the presence of DMH on several occasions. His last Encounter in 1986 ended up being my last for about 15 years due to marriage/kids/work, etc., etc. The old BT7 bought in '75 became a workbench, rabbit pen, subject of spousal irritation; always read the Flash, but didn't put an ounce of effort into AHSTC. Once a year I'd clear the BT7 off, charge the battery, and get the sucker up to running temperature to insure its potential for perpetuity – hoping maybe one of our kids would be interested in putting it back on the road....

Fat chance. In '99 I ran into Ray Donovan who mentioned he was an active Phila. Region member and a group was going up to run cars @ Pocono Raceway as part of Encounter. I told him of my car's plight – his solution was simple: get it to his house, the club will caravan; there'll be a rope in someone's trunk so my car will arrive on its own power or someone else's. In 48 hours, the BT7 was on its way up along the Delaware River, rolling on dry-rotted Dunlop rayon radials, slippy clutch, no inspection sticker...never did find out if there really was a rope!

That weekend rekindled the suppressed car-guy burning deep inside. Fast-forwarding a couple of years, an inventory of all the abandoned Healey projects I'd purchased over the last 20 years revealed a very sad (as in swiss cheese) but rare BN7 chassis. AHSTC was invited to put on a display at the Philadelphia International Auto Show in January 2002, less than 18 months away. It would commemorate the marque's 50th anniversary. A Mark II 3000 was needed and 1952 happened to be my wife's 50th birthday. This coincidence prompted a marathon restoration, which brought me in contact with dozens of clubbers whom I hadn't spent time with for over a decade. The car was sorta complete the night before it was due at the Convention Center – no drive shaft, brakes, etc., but it looked good. A couple teamsters and clubbers pushed it off a trailer into its slot of respectability, not unlike the Tucker's NY debut.

The last day of the show my wife came down to see her birthday present – Steve Jekogian snapped her reaction – that pic's now sitting beside our wedding album and last composite of the kids: a pivotal rush of elation; became our screen saver too. Since then, we've spent a large portion of our limited free time with the Philadelphia Region. Even re-made my old BT7 in time to re-run at Pocono in 2004.

For Marty & I, AHSTC has been all about the people – great times to reflect on past driving highs & lows, good food & drink at places we probably would have passed over if not selected for a regional clubber outing, and certainly, preparing for Encounter '05 and '10 along with an eclectic committee of about 16. If you haven't been to Encounter in recent years, or just forgot to register, step up to the plate immediately. There are a few rooms available at Normandy Farm: all the details are on our club website ([austin-healey-stc.org](http://austin-healey-stc.org)). When you call the hotel (215-616-8500), tell them you're with the Austin-Healey Sports & Touring Club's Encounter. Or leave a message at 610-310-2037 and we'll help you find lodging nearby. Or you can register at the door (we had 10 walk-ins in 2005). You won't be disappointed. Gordon Whitby guarantees it!

Oh yes, you'll be able to meet 3rd & 4th generation members of the Donald Healey family!  
Here's to long bonnets and your presence at Encounter '2010.



Gettysburg 2015

Photo by Chaz de Bourbon



# For Sale / Wanted



**FOR SALE 1965 Austin-Healy Sprite.** Near complete, new paint, needs finished I have the hard top and parts for a convertible. \$4,000 Call David Hutchison 717 3504253 cell , Enola, Penna. 17025. Home 717 7320048 Will send pictures. David Hutchison [wing912@aol.com](mailto:wing912@aol.com)



**FOR SALE:** I am a Healey owner for about forty years now and desiring to sell or trade my **1953 100-4**. I live in Bayport New Jersey (near Sayville.) I can be reached at either [631] 521-1347 or [631] 457-9518 Sal Lamia [timberwolfli@aol.com](mailto:timberwolfli@aol.com)

## JOE CURTO INC.

*Specializing in S.U & Zenith-  
Stromberg Carburetors,  
British Car Parts and Repair*

22-09 126th St.  
College Point, NY 11356

**718-762-SUSU (762-7878)**

**FAX: 718-762-6287**

**[www.joecurto.com](http://www.joecurto.com)**



**HELP WANTED:** Full time ( part time considered) assistance in assembling small components, assembly of rebuilding kits and disassembly of automobile carburetors for cleaning. Packing items for shipping etc. Detail orientated Located in Queens New York .Contact Joe Curto 718 762-7878 or [joecurto@aol.com](mailto:joecurto@aol.com)

# For Sale / Wanted

Going Concour with a 3000. You may need these. For Sale original stowage bages. Tonneau cover and boot (top) storage cover.

Excellent condition Used in my concour and my 3000 achieved Gold. \$ 200 for both Steve jekogian [stevejekogian1@gmail.com](mailto:stevejekogian1@gmail.com)

Bugeye Project car frame motor, trans, rear, lots of parts for restoration or racing. Rust in the usual places. Photos available PA title First \$500 takes it [stevejekogian1@gmail.com](mailto:stevejekogian1@gmail.com) Or \$150 for motor 948. \$150 for smoothcase trans \$150 for rear.



Bugeye Fiberglass Bonnet. Never on a car. 25 to30 years old –so it was made well perfect condition \$600 [Stevejekogian1@gmail.com](mailto:stevejekogian1@gmail.com)

I dismantled an AH 3000 last year for ground up resto. chassis was shot I don't want to fork out \$12000 for a new one So I am selling it. 32,000 mls on 3 carb overdrive engine. whole car sans seats and chassis highest offer gets all. I need room for 1937 MG-VA ground up resto. Ian Arnott. Must sell soon don't make me e- bay it guys. [Boeinglad1@yahoo.com](mailto:Boeinglad1@yahoo.com)



Modified 1958 100-6 Healey. Upgrade list, resto finished rust free in 2010, 350 chevy V8, 700R4 trans, 9" posi rear, 4 wheel disc brakes,chrome wheels, all chrome is new, hardtop, soft top & cover, large oil cooler. Looks stock until you push the button. Call John Koch 302-439-3932 John Koch [johnhealey106@yahoo.com](mailto:johnhealey106@yahoo.com) Asking \$34,000

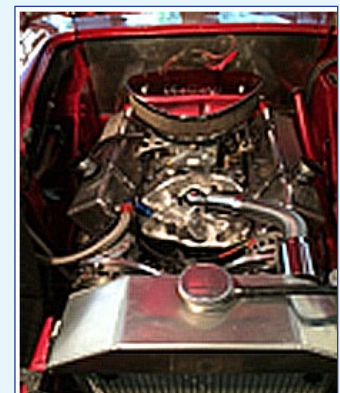

1965 Austin-Healy Sprite . Near complete , new paint, needs finished I have the hard top and parts for a convertible. \$4,000 Call David Hutchison 717 3504253 cell , Enola, Penna. 17025. Home 717 7320048 Will send pictures. David Hutchison [wing912@aol.com](mailto:wing912@aol.com)

I am a Healey owner for about forty years now and desiring to sell or trade my 1953 100-4. I live in Bayport New Jersey (near Sayville.) I can be reached at either [631] 521-1347 or [631] 457-9518 Sal Lamia [timberwolfli@aol.com](mailto:timberwolfli@aol.com)





# OVER 300 HEALEY'S RESTORED FIXED PRICE RESTORATIONS



## BIG HEALEY'S WANTED any condition!

RESTORATIONS, SALES, SERVICE, PERFORMANCE UPGRADES

Healey 5 Speed, Hendrix Wire wheels, Kilmartin Chassis replacements



**British Restoration Corp.**

2231 East Ontario Street

Philadelphia, PA 19134

Cell: 917.257.3410

Office: 215.291.9666

[www.britishrestorationcorp.com](http://www.britishrestorationcorp.com)

# SEATS STUCK!

By Steve Jekogian

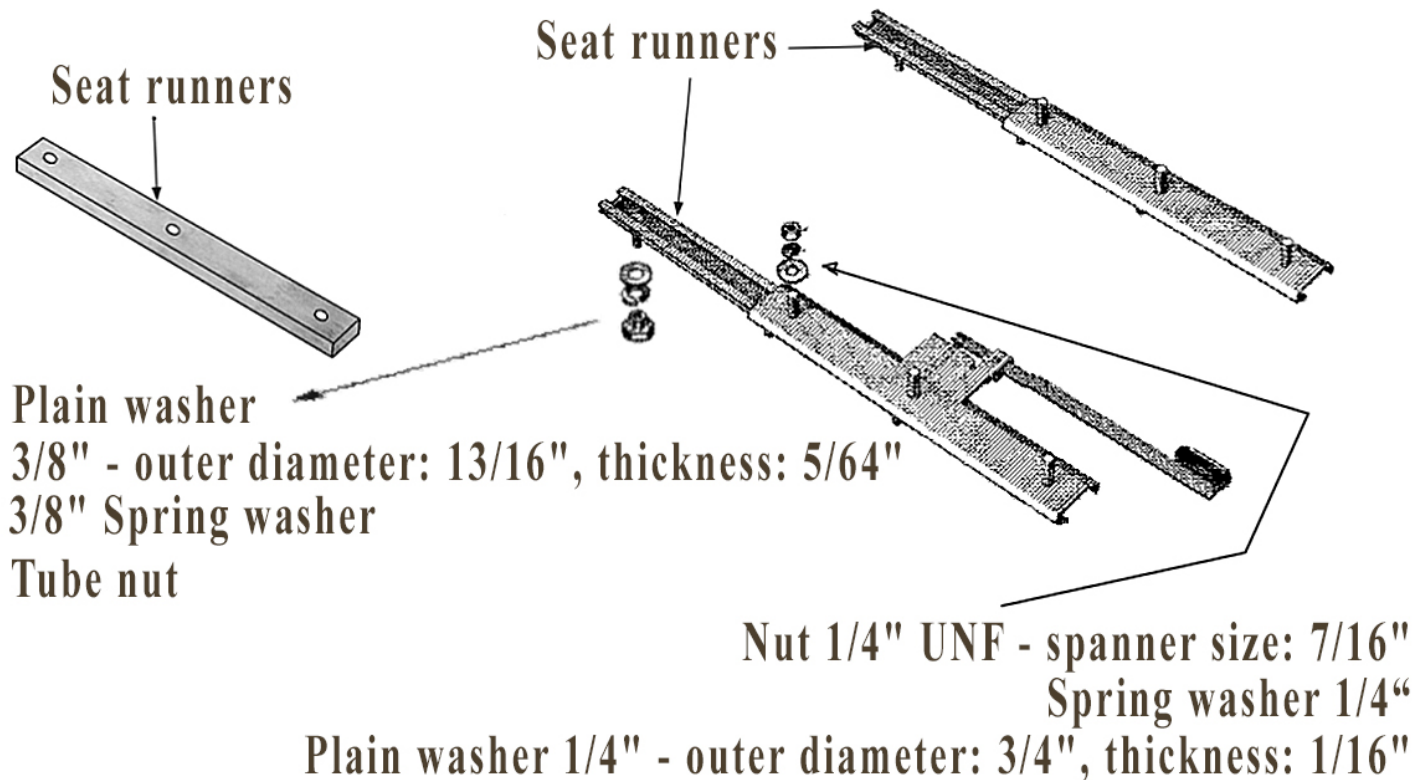

**L**ots of Healeys I sit in have a common problem – the seat tracks are frozen solid or take a lot of effort to move. It seems that the passenger side is worse, perhaps because it gets moved less often. Do you want your seats to glide like they are supposed to? Do you want people to get in your car and feel comfortable being able to move the seats around and you don't have to make excuses. New seat rails aren't cheap, about \$90.00 a pair.

This Tech article, will explain how to repair and refurbish your seat rails so they glide into position with no effort at all. The seat rail repair is a simple job that can be done with just basic tools that you already have. First remove the seat bottom and then the six nuts that hold the seat back on. Now jack up the car and from below remove the six bolts that hold the seat rails in. The passenger side is easier – no exhaust pipes to contend with. Under the rails are a piece of wood and a sheet metal strip save them if you can. Once the rails are out determine how much you have to take them apart. If really frozen or if some bolts are broken you should separate the top and bottom rails. To do so put the seat rail in a vice and knock the pins out of the bottom rail using a nail punch, then remove the 8 ball bearings (four per end) by sliding them out the ends. Now the two rails can be separated. Wire brush or sand blast the rails to clean them up. To replace broken bolt on the top rail use a grinding wheel to grind the head down on the inside and then what's left of the bolt on the outside. Once flat put in a vice and use the nail punch to knock out the bolt. On the bottom rail you can not get the grinding wheel inside so ground down the bolt as far as you can and use the nail punch to knock it out.

To replace the bolts find a bolt of the right length and threads and grind down the head till it is about the thickness of a quarter. Now find a friend with welding equipment or ask your gas station guy to tack it in place. The seat rails were originally cad plated a silver color, so a little silver paint should be a close match. Use some white lubricating grease on the rails and the adjusting mechanism and put two ball bearings in one side of a rail then wiggle the rail to insert the other two on the same end. Masking tape on the ends of the rails can help keep them in place. Now reinsert the retaining pin and hammer into place. Do that for the other side and your done. Reinstallation is, as the repair manual says, " a reversal of removal". The wood piece is 3/8" thick if you have to replace yours and is wood colored. The sheet metal piece goes under the wood, and now is a good time to scrape and paint the floorboard in this area prior to bolting it all back together. 🇬🇧





# Directory

## CORPORATE PRESIDENT

Ray Donovan  
215-699-8355  
president@ahstc.org

## CORPORATE MEMBERSHIP

Rick Brodeur  
215-536-6912  
membership@austin-healey-stc.org

## CORPORATE SECRETARY

Del Border  
717-235-1086  
delborder@comcast.net

## HARRISBURG REGION

President	Editors	Meetings
Joe Spear	Fred Bennett	3rd Tuesday, 6:30PM
717-272-8343	(717) 635-8083	Watch E-Flash
bjspear1@verizon.net	thinwaterpaddler@yahoo.com	for Location

## LEHIGH VALLEY REGION

President	Editor	Meetings
Ken Beck	Ken Beck	3rd Monday
kenbeck@rcn.com	kenbeck@rcn.com	Watch E-Flash
		for Location

## PHILADELPHIA REGION

President	Editor	Meetings
John Heffron	Randy Alkins	3rd Monday, 7pm
215-300-4023	215-343-2785	Metropolitan Diner
john.heffron@hotmail.com	randyalkins@gmail.com	

## BRANDYWINE REGION

President	Editor	Meetings
Chuck Ott	Ernie Leser	Watch E-Flash for Date,
302-378-7287	410-398-7308	Time & Location
chucknsueo@yahoo.com	ernstleser@verizon.net	

## NORTH JERSEY REGION

President	Editor	Meetings
Steve Feld	GeorgeCrombie	Watch E-Flash for Date,
973-206-1973	908-243-0693	Time & Location
stenergy@optonline.net	george_crombi@yahoo.com	

## LONG ISLAND REGION

President	Editor	Meetings
Paul Parfrey	Paul Parfrey	Watch E-Flash for Date,
718-353-8138	718-353-8138	Time & Location
workshealey@aol.com	workshealey@aol.com	

## CORPORATE TREASURER

Gerry Kunkle  
610-867-6955  
agkunkle@aol.com

## FLASH EDITOR

Steve Jekogian  
201-213-8217  
Stevejekogian1@gmail.com

## REGALIA

Trish Woglom  
610-310-2037  
pwoglom@comcast.net



## CONTRIBUTIONS

AHSTC encourages the submission of articles to the Editor for publication. There is no restriction on content, other than it should be of interest to the readership and Healey related.

## MEMBERSHIP & SUBSCRIPTIONS

The AHSTC is a non-profit, Pennsylvania corporation dedicated to the preservation of the Austin Healey marque. Contact Rick Brodeur or a region president to inquire on membership.

## ADVERTISEMENTS

25 word, non-commercial classified ads run for 3 months and are free to members. Non-member classified rates are \$0.20 per word. Commercial Advertisers please contact Bob Snyder at 610-216-7787 or [rjs1@desales.edu](mailto:rjs1@desales.edu)

## NEWSLETTER DEADLINE

Contributions & advertising must be received by the editor prior to the 25th of each month for inclusion in the following month's issue.

## CONTRIBUTING EDITORS

Send contributions and ads to Steve Jekogian [stevejekogian1@gmail.com](mailto:stevejekogian1@gmail.com)

## DISCLAIMER:

*The Austin-Healey Sports & Touring Club, its Board and members assume no responsibility for the accuracy of advertisements listed in this issue of The Flash.*

*Technical Articles that appear on this site are the opinion of the authors and do not necessarily reflect the views of the AHSTC.*

*Products and Services advertised on this site are not necessarily endorsed by The Austin-Healey Sports & Touring Club, its Board or membership. Complaints or inquiries should be forwarded directly to the advertisers.*

*All purchases are at the complete discretion of the consumer*