

The *FLASH*

JUNE 2018 | ISSUE 482



OFFICIAL PUBLICATION OF THE AUSTIN HEALEY SPORTS & TOURING CLUB

JUNE • 2018

CONTENTS

- 3 CLUB | *Editor • What's In The Flash*
- 5 REGION | *Harrisburg*
- 7 REGION | *Philadelphia*
- 9 REGION | *Brandywine*
- 10 REGION | *Long Island*
- 12 REGION | *North Jersey*
- 16 REGION | *Lehigh Valley*
- 19 ARTICLE | *Seats Stuck*
- 21 CLUB | *Members Corner*
- 24 CLUB | *ENCOUNTER 2018*
- 29 BUSINESS | *Classifieds*
- 32 CLUB | *Membership Application*
- 33 CLUB | *Directory*

HYPERLINKS ARE ACTIVE
THROUGHOUT THE FLASH.



THE FLASH

CORPORATE OFFICERS

*President: Ray Donovan
Membership: Rick Brodeur
Secretary: Del Border
Treasurer: Gerry Kunkle
Flash Editor: Steve Jekogian*

HARRISBURG REGION

*President: Joe Spear
Editor: Fred Bennett*

LEHIGH VALLEY REGION

*President: Ken Beck
Editor: Gerry Kunkle*

PHILADELPHIA REGION

*President: John Heffron
Editor: Randy Alkins*

BRANDYWINE REGION

*President: Chuck Ott
Editor: Ernie Leser*

NORTH JERSEY REGION

*President: Steve Feld
Editor: George Crombie*

LONG ISLAND REGION

*President: Paul Parfrey
Editor: Paul Parfrey*

Copyright 2018 AHSTC©



LIKE ON FACEBOOK

ON THE COVER

DOWN SHOT OF THE FIRST EVER
COFFEE AND CRUMPETS.

What's In The Flash

Steve Jekogian

Carlisle never disappoints. "They" said rain and we did not go on Friday, but it was OK and not crowded according to the "hard core" goers. Saturday was another story.

The first ever Cars and Crumpets was held on May 20 in Parsippany New Jersey. Like all British car events it started small, but I am sure will grow and grow as AHSTC and Coffee and Croissants did.

Ralph Scarfogliero from the North Jersey region, came up with a great idea and he is making it work. On a slightly overcast Sunday morning a bunch of "British car guys and gals" showed up for the event.

Below is the write-up on the Cars & Crumpets website
NJBC.ORG

Cars & Crumpets May 20, 2018

May 22, 2018

It was a typical foggy English morning with scattered showers in the forecast for the early morning. They predicted it to clear up by 9am, with some sunshine, and rain to return in the late afternoon. So in good old British fashion I decided to keep calm and carry on with the inaugural Cars and Crumpets gathering.

Along the way to the event one of the showers crossed my path for about 20 minutes . Not to be deterred I continued to the location. After setting up, and raising the Unionjack the skies cleared up and the sun was shining. After a few minutes the first of the courageous drivers who disregarded the dreaded weather reports





started to show up. Albeit in coupes or with their tops up. However after the first hour a few more adventurous drivers did show with their tops down.

In all there were 10 drivers who ignored the ominous weather reports to attend. One gentleman wandered over to check out the event, and he told me he found out about it from his friend in New Zealand ! I guess the interest for this exclusive British car event is gaining popularity. One gentlemen brought his young son, and he received a model of an Aston Martin, similar to the car his dad drove him in.

I want to thank all the brave attendees for coming to the inaugural event. Please help spread the word to all your British owner friends .

Next month there will be 2 gatherings at this same location (New Jersey route 10 and 202 at the Dunkin Donuts), on Sunday June 10th, and June 24th. Hope to see you there.

I am sure that Ralph (ralph@natroute.com) would like All the AHSTC regions to set up their own local **“Cars and Crumpets”** events.

Good driving



HARRISBURG

REGION

By Fred Bennett

Whatever Happened to Spring?

Yeah, I know... "April showers" and all that. That would be "normal." But whatever happened to the "merry, merry month of May?" Remember learning about "continental drift" in school? Well, it's occurring at an alarming pace these days! Apparently, the Northeast US is now located where Seattle used to be.

Today is Saturday, May 19th- Carlisle Import and Performance day- one of the highlights of the driving season, when the Harrisburg Region always hosts a pot-luck lunch for all our Healey friends under our tent. Carlisle represents one of the largest gatherings of British sports cars you will ever find in this area. Yet, as I cower in my dimly lit garret (instead of attending the Carlisle show) scribbling this month's Flash article to the incessant pitter-patter of rain on our tin roof, it occurs to me that it has rained seven out of the last seven days! In fact, there has not been a period of more than two days in a row without some kind of precipitation for over two months. I wonder what the Healey clubs in the Southwest have to complain about... maybe the heat? To heck with spring!

Upcoming Events

"Hope springs eternal in the savage breast," so I'm choosing to look ahead to summer and all the wonderful driving opportunities to come. Our annual "Ladies Night" and cruise-in at the Soda Jerk in Hummelstown is scheduled for June 19th at 6:30. The summer picnic is tentatively scheduled for July 21st in beautiful Fishing Creek Valley. Of course, the pinnacle of the Healey driving season will be Encounter on September 19th – 22nd in Lancaster, PA. In the meantime, I intend to squeeze as much seat time as possible in between the raindrops and hail stones. Oh, and I just ordered a new set of wiper blades for both the Sprite and the BT7, just in case this crazy weather sticks around.



Don and Susan at Carlisle

**A Final Exhaust
Note • In Memoriam
Donald Nalley
March 15, 1933- May 6, 2018**

Our AHSTC community was sad to learn of the passing of long-time member Don Nalley on May 16th. Don was a dedicated and passionate Healey enthusiast. Just last year, even as his health was failing, he saw the total restoration of his stunning BJ8 through to completion. Although Don would not be able to fully enjoy that car himself, he has left behind a beautiful, historical artifact of a motoring tradition that he dearly loved and will be greatly appreciated by generations to come.

Don was a stalwart member of AHSTC for over twenty years, during which time he enjoyed attending numerous Encounters, Progressive Dinners, Annual Award Banquets, the Carlisle Import Show, and the Hershey meet. He and Susan were regular guests at the Grand Poo Pah and Moo Pah Bed and Breakfast Inn for many Healey events. In his non-Healey life, Don was an accomplished architect in the Washington D.C. area, where he was born and raised and attended Catholic University. He continued to work and live there his entire life, with the exception of the two years he served in the U.S. Army as an illustrator at Fort Gordon in Georgia.

Our thoughts and prayers go out to our good friend and his dear wife, Susan, who was no less enthusiastic about their shared passion for these special automobiles. Don is also survived by a stepdaughter, Sarah Murray, and step-granddaughter, Tina Noelle Robinson. We will all miss Don's dry humor as well as his vast knowledge of the Healey marque.

Fred Sherk, who knew Don for many years, sends the following tribute: Don Nalley was a true gentleman. He was the perfect straight man for Susan, who can tell a joke as well as any comedian. He was a great representative of our club, whose latest restoration of a BJ8 was outstanding. We are going to miss him.

Mary Ann Waltz sent along these sentiments: So sorry to hear of Susan's loss and our loss too. Don was a terrific guy and a gentleman. I will always remember him.



"Don and Susan are 'in it to win it' at the 2010 Funkhana!"

*Through countless miles and winding lanes,
Gymkhanas, ralleys, tight chicanes-
On tours with the pedal down,
We roared and thundered through each town!*

*This solemn journey you now take,
Is one we, someday, all will make.
Yet, know the road ahead this day,
Is paved with friendship- all the way.*



"Don and Susan with their Big Healey at the Revere Hotel, Encounter 2010"

PHILADELPHIA

REGION

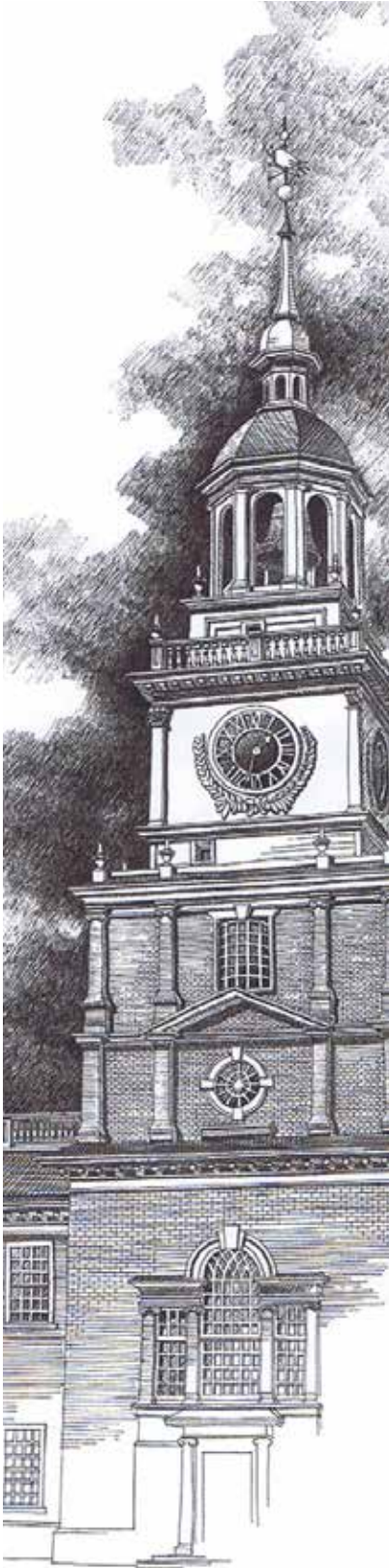

Finally, spring sunshine has arrived, and temperatures are rising. Time to uncover the Healeys, clean them up, and get them on the road.

We have had a few tech sessions in the past month, including one rainy Saturday at Paul's garage. At that time, Ray and the group proceeded to take the Bugeye on the forklift out of the garage into the parking lot. Then, using plenty of truck-soap, they proceeded to power wash the engine bay, underneath of the chassis and the rear area to remove decades of built-up grime, dirt, and who knows what else. Everyone was happy with the outcome.

A week later, we traveled to Terry's house to work on tuning up his BJ8. We readjusted the points and attempted to determine the proper timing setting. Multiple books gave different settings as the proper timing. What I did find out was that from

top dead center, five degrees advance is $17/64$ " and 10 degrees was $17/32$ ". Forget all that—it's a $1/4$ " or $1/2$ ". We also proceeded to disconnect all linkages from the carburetter (British spelling) and reset them as per the SU Manual.



These tech sessions have turned into genuine gourmet outings. We have dined on barbecued ribs with

all the “fixins”, pulled pork sandwiches, and the third session included meatball and sausage sandwiches. This has perked the interest in attending tech sessions. We’re waiting to see what’s next.

We are looking for more tech sessions to be held weekends this summer. Let me know what you need, and we’ll try to schedule it. Remember, there are high standards now for food.

A Cars and Coffee event was held at Pour Richard’s on Sunday, May 6. In spite of impending rain, a few people arrived in their regular waterproof cars to enjoy good coffee, pastries, and conversation.

Upcoming events include the annual club picnic on Saturday, June 16 (raindate June 17) at the home of Donna and Terry McNelis, beginning at 2 p.m. Please RSVP to Terry ASAP so that an accurate count can be made. A flyer has been circulated by eflashes, so please check them.

Upcoming shows of interest include Newtown Antique and Classic Auto Show, Sunday, July 15. Space is limited so be sure to sign up soon. The following Saturday, July 21, is Doylestown at Dusk, an evening car show from 5 to 9 p.m. The town will be open, and again there are limited openings, so sign up soon.

The Mercer Museum in Doylestown is exhibiting “Racing: Need for Speed,” between now and September 9. On July 28, there is a special event there concerning dirt track racing during the 1950s and 1960s at Langhorne Raceway.

The next meeting at the Metropolitan will be June 18, at 7 p.m.



PASSION
IT'S WHAT DRIVES US.



BRITISH AUTOMOBILES • PREMIUM RESTORATIONS
203 S. 4TH STREET, PERKASIE, PA 18944 215-257-1202 • RAGTOPS.COM

PROVIDING SERVICE,
TOURING PREPARATION
& CONCOURS
RESTORATION FOR YOUR
AUSTIN HEALEY

- PERIODIC ATTENTION
- CARE & ADJUSTMENT
- FLAWLESS COACHWORK
- COMPONENT REBUILDS
- SAFETY UPGRADES

Since 1990
RAGTOPS & ROADSTERS
INCORPORATED

WANTED
AUSTIN-HEALEY
100-4, 100-6 or 3000
Any Condition; Top \$ Paid; Finders Fee Paid
Pick Up From Anywhere In the US
GULLWING MOTOR CARS
1-800-452-9910 ask for Peter Kumar



Brandywine

Your regular Brandywine region newsletter editor, Ernie Leser, is off touring Europe again this month, so he asked me to step in and report on the two Brandywine region events that occurred in May.

The first was “The British Are Coming – Again” car show and parade in Lewes, DE. It was a beautiful day for driving Healeys. Brandywine Members Mike Tyler (Blue BT7 Tricarb), Chuck Ott (Blue AN9 Sprite), Jim Martin (Red BJ8), John and Nancy Montague (Blue/Blue BT7 Tricarb), and TL Wright (Green/tan BT7 tricarb) had cars in the show. Roger Bono and Ian Hall were there to see the show, but neither Ian’s Sprite nor Roger’s BJ8 is road ready just yet. The cars were parked



on a grass field on the grounds of the Ferry terminal, with all of the terminal facilities, including restaurants, within walking distance. There was also a free shuttle to downtown, which we didn’t find time to take. Chuck Ott won 2nd place in the “Featured Marque” class, which is the Austin Healey Sprite. There were only 2 other cars in the class, a red bugeye that won Best of Show, and a red 1962 squarebody Sprite. The show included a British car parade through downtown Lewes before heading home.

The second event was the Carlisle Import show in Carlisle, PA. While there was rain forecast all day, we still had a contingent show up. Chuck Ott, Steve Garrett, and Jim Martin attended from the Brandywine region on Saturday. It turns out that it was cloudy all day on Friday and didn’t rain, but we figured out too late that this probably would have been the better day to go. Chuck did not enter a Healey in the show, but instead entered his 1985 VW Vanagon camper. A much better vehicle to drive in the rain! The rain did subside by late morning, and there were still quite a few people at the show. The rain didn’t seem to discourage the closed cars, and even a few convertibles showed up. There were certainly no cars with convertible tops down, except for the ones in the display building. We did meet with a few AHSTC members from other regions, did the passport activity and checked out the display building cars. Chuck scored a windshield / frame assembly to upgrade the one in his BJ8. In the end, we still had a good time getting together with our Healey friends.

UPCOMING EVENTS

Next Saturday, June 2, is the Cars & Motorcycles of England show at Hope Lodge in Fort Washington, PA. This is a joint show between the Delaware Valley Triumph club and Delaware Valley Jaguar club, and is a very large show with around 250 cars and motorcycles entered. I haven’t been to this show in 20 years or so, but it always gets rave reviews. This is the Jaguar Concours d’elegance in addition to a multi-marque British car show. Roger Bono and I are planning to go in his Jag. Hope to see you there! See this website for more details. <https://www.dvtr.org/cmoe/>

The next event in June is the June 5 tour to Luray. Contact Chuck Ott for further info.



Long Island

REGION

May 20th was the day of the Bayport Aerodrome Transportation Show – airplanes, cars and motorcycles. So many events have been canceled or postponed lately due to weather, and whether this event would go off as planned or be put on hold till July was a question up till the last minute. A number of Long Island Region members showed up. Mary Ann Sekelsky and Tedd Krummeck worked at the show as Tedd is a regular volunteer at the Aerodrome. Other attendees were Frank Filangeri, Ira Udasin, Tony DiFrancesca. and myself. I found it very enjoyable to see all this old stuff. There was good food for sale, a band to entertain the crowd, and a raffle for a flight in a Boeing Stearman, two seat biplane. That aircraft was World War II's primary training plane so this was the first type of plane a pilot would encounter on the ladder to bigger and faster training planes.



Mary Ann and Tony

Scott Greenfield's BJ8 had a starting problem this spring. It ran for a couple of seconds and then refused to start again.



Frank's Jaguar and my walker

Over the phone, he and I went through all the things that could keep it from starting but nothing we came up with helped. So before he sent it anywhere to be looked at, I said to try one more thing. That was to whack the bulkhead below the rear seat on the right side of the car because the fuel pump lives on the other side of that bulkhead. You can use a hammer or your fist. If it's the points on the fuel pump, this will possibly wake them up and all of a sudden you will hear click, click, click, click... and your carburetor fuel bowls will fill up and the car will start. There are now solid state fuel pumps that do not have points. However, almost all the old timers whom I spoke to about this said they would buy a new pump with points. The reasoning being that if the solid state pump stops, this trick

won't awaken it, whereas if there are points, this could work.

A new pump with points will last many years before this problem will rear its ugly head again. Your choice. As far as other Healeys go, BJ7's have the pump on the right side also; however, BT7's and BN7's and 100-6's have the pump on the left side over the exhaust.

Heads up: it looks like the Annual Beach Run/Sunset Tour will be on Thursday, July 12th. More information will be forthcoming as the date approaches.



Boeing-Stearman US Navy N2S



Radial Rhapsody - Do you get it?



North Jersey

By George Crombie

Another club member is gone,

Michael J. Venezia, Jr. "Mickey" '86, passed away on May 19, 2018. He became active in the club after his son, Dave Venezia, passed away suddenly.

Is it June already?! Where the heck did Spring go? All I know is that we are well into the Car Show Season, having every weekend in May staked out with either a show (Brit Fest on May 5th), a Tech Session (at Paul Olson's in Whitehouse, NJ on May 12th), an event (Carlisle Imports in Carlisle, PA from May 18 through the 20th), a gathering (Cars and Crumpets on May 20th), or a tour (May 27th) earmarked for something to do other than mowing the lawn. Or getting too greasy. Add to that our monthly Club Meeting on Tuesday, May 8th, and it's no wonder Spring has flown right on by and become Summer! It might be best to start at the beginning, of May at any rate.

This year's Brit Fest was held on Saturday, May 5th in Succasunna, NJ. Members attending included Steve Feld (BT7), Ralph Scarfogliero (MG TD), Steve Jekogian (BJ8), Tom Mulligan

(E-Type Jag), new

members Alan & Nina Harris (BJ7), and potential new members, Josh & Rita Landsman. My notes indicate that Steve Jekogian scored a 3rd place with his red over black '65 BJ8 and Alan & Nina Harris took home 1st with their '63 BJ7. My apologies if I left any one out. You really should see some of the notes I take!

This was followed by our Monthly Club Meeting on Tuesday, May 8th at Charlie Brown's in Chatham, NJ. We had a pretty good turn-out at the meeting, including Steve Feld (BT7), Bill Geissel, Allen Rosenberg, Tom Mulligan, Art Herkomer, Richard Ippoliti (100-6), Ralph Scarfogliero, Frank Dapiran, Rudy Hyzer (MINI), Larry Gersten (MINI), Ian & Sue Kessen, Ernie & Marion Marateo (MINI), and George Crombie. Topics at the meeting touched on the up-coming Red Mill All British Car Show (Sunday, June 3rd), volunteers needed, and are always welcome; a tech session at Paul Olson's; Carlisle Imports and Performance weekend; the inaugural Cars and Crumpets; North Jersey's annual Spring Tour, the PA area's All British Reliability Run for this year, as well as upcoming events into June and July, with a push to register early for this year's Encounter in Lancaster, PA in September. Following the meeting, Steve Feld put Bill Geissel on the spot,



and Bill entertained us on his introduction to British cars, and Healeys in particular. The meeting wrapped up with a recap of last year's All British Reliability Run (henceforth called ABRR, as my poor little fingers are getting worn out with all this typing), with Richard Ippoliti and Frank Dapiran regaling us with their exploits. Definitely a "bucket list" type of event!

Paul Olson hosted a Tech Session at his home in Whitehouse, NJ. No, not that White House. The purpose was to install the engine and transmission into his (new to him) 1962 AN7 Mark II Sprite. Such a long name for such a sprightly little car! Paul had the car prepped, ready, and sitting on blocks; so, after bagels, munchkins, and coffee, the work was begun! Joining Paul were Bob Pense, Larry Gersten, Ralph Scarfogliero, Steve Feld, John Moore, Rudy Hyzer, Paul's friend and neighbor Bill Tuma, and George Crombie. After hooking the engine up to the hoist, Larry volunteered to crawl under the Sprite to handle operations from that end. Almost immediately, Larry voiced a complaint: "I can't work on this...It's too clean under here!" Since he was flat on his back, and the rest of us had really big boots, he was at a distinct disadvantage. Needless to say, he stayed under the car. Some of the rest of the crew pitched in and manned the hoist, while the remainder (including me?) managed to



BEHIND YOU ALL THE WAY!

TCARGO

TRAILER SALES
 .com

Trish & Paul Woglom
 801 West Eighth Street
 Lansdale, PA 19446

CALL US TODAY
 (800) 220-7913

Motorcar Garage
 Repair-Maintenance-Restoration
 British Car Specialist

Peter Cosmides
 42 North Pine Ave.
 Maple Shade, NJ 08052
 Phone: 856-667-6657

www.Motorcar-Garage.com

BRITISH MOTOR TRADE ASSOCIATION

Universal
 VINTAGE TIRE CO.
Expert Vintage Tire Sales & Service Since 1968

**THE BEST QUALITY SELECTION OF
 TIRES & WHEELS
 FOR YOUR AUSTIN HEALEY**

VEDESTEIN
AVON
 DAYTONA

SAME DAY SHIPPING
from Hershey, PA
 on in stock items
 ordered before 12 noon EST

OUR TIRE PROS ARE HERE TO HELP
1-877-295-2055
universaltire.com

look busy drinking our coffee. Did I mention that it was a very wet and rainy day? No one drove British; unless maybe Rudy. I had planned to drive Red, in case we needed to compare connections, but the skies opened up and dumped on me just before I backed the Sprite out of the garage, so I drove my Toyota. After seeing Paul's AN7, there were enough differences that it wouldn't have made a difference. Except I would have been a wee bit wetter. Did I mention that it was a very wet and rainy day? I'm sure I did. I might even mention it again; but not right now; I'll keep you in suspense. The operation was a success and went without a hitch. Oh, the advantages of having someone(s) who know what we're trying to do! Paul has a few other little projects to do on his Sprite (brakes; electrical connections; throttle...) during the next few weeks and has hopes of having it on the road by the middle to end of this summer.

Several members had arranged to join up and drive out to Carlisle, PA on Friday, May 18th to see what kinds of bargains could be had at the annual swap meet, but the inclement weather (yes, more rain!) put a kibosh to those plans. I don't know if anyone made it out on their own, but the organized trip was cancelled.

Ralph Scarfogliero hosted his inaugural Cars and Crumpets on Sunday, May 20th. From the reports I heard, nine British cars braved the morning rain (it cleared up by around 9:00 am), with 10 or 11 people attending. Four Healeys: Steve Feld (BT7); Steve & Lynn Jekogian (BJ8); Richard Ippoliti (100-6); and Patrick Venezia (BJ8); two MINIs: Ernie & Marion Marateo; Richard Miller, a Jag, an Aston Martin, and Ralph with his MG TD rounded out the crowd this day. For Ralph's write-up and more pictures, check out Ralph's website:





njbcc.org and join the group! Ralph mentioned that one of the people who stopped by told him that he had heard about the Cars and Crumpets event from a friend in New Zealand! Impressive, to say the least. The next two Cars and Crumpets events are scheduled for Sunday, June 10th and Sunday, June 24th. These weekends are on either side of Father's Day.

As I write this (Friday, May 25th, at the deadline, naturally), the next event on our calendar is our annual Spring Tour, in 2 days. This takes place on Sunday, May 27th starting at 10:00 am at The Grain House in Basking Ridge, NJ. Rudy Hyzer has organized a short little run of about 50 miles or so through Somerset, Morris, and Hunterdon Counties, with lunch at the Black Horse Pub in Mendham. This run is dedicated to the 60th Anniversary of our beloved little Sprites. I think the weather will dictate just how many Sprites will join us. If you didn't make it out to this event, you may be able to read all about it next month. Of course, nothing beats getting the news first hand!

ANOTHER QUICK NOTE: IF YOU ARE A MEMBER

Next on the agenda: June 9th is A Touch of England, held in HoHoKus, NJ and sponsored by NJ Triumphs. June 10th is the British Motorcar Gathering in Hellertown, PA and sponsored by the Keystone MG Club. June 10th is also the second edition of Ralph's Cars and Crumpets; check out www.njbcc.org for info. June 12th is North Jersey's Monthly Club Meeting, held at Charlie Brown's in Chatham; starts at 7:00 pm. June 20th we will try to gather for an Ice Cream Social; this is on a Wednesday; check your e-Flashes. As always, stay tuned to your e-Flashes from Steve Feld for the latest on what's happening and where!



Lehigh Valley



On Saturday April 29th the British Car Club of the Lehigh Valley held its annual garage tour except this year it was called "Engine Turned Garage Tour". After meeting at my home for coffee, juice and donuts we traveled to Leydon Restorations in Lahaska, PA. Following detailed directions prepared by Allen Hess we drove route 212 to just South of Riegelsville, turned south on 611 to route 32 which is the scenic drive along the beautiful Delaware River through Upper Black Eddy, Erwinna, Point Pleasant and Lumberville before turning unto route 263 to Lahaska.



Leydon Restorations specializes in the mechanical restoration of pre-and postwar European marques. In the shop were a Bugatti, Ferrari, Lozier and a Triumph TR6 with California plates. The Triumph looked a little out of place but the car was in the shop for the usual items to make it road worthy.

Eric Peterson and staff gave us a tour of the shop which features engine dyno testing, precise machining and parts reverse engineering.

A very nice lunch was enjoyed at the Plumsteadville Inn which faces route 611, Easton Road. Some participants traveled to O Wow Cow on for ice cream. O Wow Cow is located at the intersection of PA 563 (Lake Nockamixon) and Pa Route 412.

Upon returning home I thought I had some letters on Leydon letterhead in my files. It turns out that Leydon had done a paint job on my BJ8 in 1982. At that time they appraised the value of my car at \$13,000. Ten years later they estimated the fair market value at \$25,000. A pretty good return if only the value continues to increase \$12,000 every ten years my car must be worth? Maybe I should call Hagerty and increase the coverage.

I would be glad to lead a rally /drive similar to the one the BCCLV put on, excluding the visit to Leydon, for the Lehigh Valley Region if there is any interest. Please contact me.

On May 5th I attended Britfest 2018 put on by the MG Car club Central Jersey Centre, Inc. at Horseshoe Lake Park Succasunna, NJ. They were celebrating the 50th anniversary of the Jaguar XJ. From Bethlehem the trip is about an hour and a half. I always have to look at the map and google the park to prepare for the drive. Upon arrival I saw Tom Mulligan and his beautiful Series 1 XKE 3.8 OTS and Russ Kramer's XK140 Drophead Coupe in the Jaguar section. Austin



Healey's were well represented. I counted four Jensen Healey's which is a rarity. They were all nicely restored though one of the Jensen's had brake light problems. The North Jersey Region was well represented. I counted ten big Healey's. Bob Whitbeck represented the Lehigh Valley Region. Pictures of his green 1967 car are included with this Flash. There were two very nice bug-eye Sprites in a class of their own.

Hope you have had a chance to visit America on Wheels at 5 N. Front Street, Allentown. If not the Cars of Rick Hendrick are featured in the changing gallery. The cars featured are Jeff Gordon's #24 2008 Chevrolet Impala, "DuPont Flame", Jimmy Johnson's #48 2012 Chevrolet Impala sponsored by Lowe's and Dale Earnhardt's 2008 Chevrolet Impala #88 sponsored by National Guard. The Chattanooga Chew #16 1989 Buick Regal driven by Larry Pearson as is the 1979 Chevy Nova #15 driven by Geoff Bodine sponsored by "Levi Garrett" is also on display.

The Lehigh Valley Region held its monthly meeting at Rudy's in Bethlehem, Attending were Ken and Cindy Beck, Rick Brodeur and yours truly. We discussed Encounter 2019 and



concluded that Lehigh Valley is unable to run Encounter due to having no chairperson and lack of member support. Again due to lack of attendance we have suspended our monthly meetings for the time being. Members are invited to the British Car Club of the Lehigh Valley picnic on July 5 at the Spring Valley Sportsmen's Club which is only a mile or so from DeSales University. Additional information and directions will be forth coming.



www.BritishWiring.com

British Wiring



Suppliers of Wiring Harnesses, Wire, Terminals & Sundries
for British Classic Cars and Motorcycles

Toll Free: 866-461-9050

Fax: 610-845-3518

email: sales@britishwiring.com

P.O. Box 185 • 617 Walnut Street • Bally, PA 19503



www.BritishWiring.com

TRIUMPH RESCUE

Parts • Service • Restoration

610-845-8217

Fax: 610-845-3518

617 Walnut Street

P.O. Box 185

Bally, PA 19503

email: triumphs@triumphrescue.com

- ❖ MG's
- ❖ Jaguar
- ❖ Austin-Healey
- ❖ Land Rover
- ❖ Triumph
- ❖ Aston Martin



Healey Surgeons

7211 Carroll Avenue
Takoma Park, Maryland 20912

(301) 270 8811

E mail: enquiries@healeysurgeons.com

come visit us on our website:

healeysurgeons.com

for tech tips, tech chats,
download price list, check on current prices
and on line ordering

Parts • Service
Restoration for 100-4 to 3000 Mark III

Bruce and Inan Phillips

J.C. TAYLOR

ANTIQUE INSURANCE

1-888-ANTIQUE

JCTAYLOR.COM



SEATS STUCK!

By Steve Jekogian

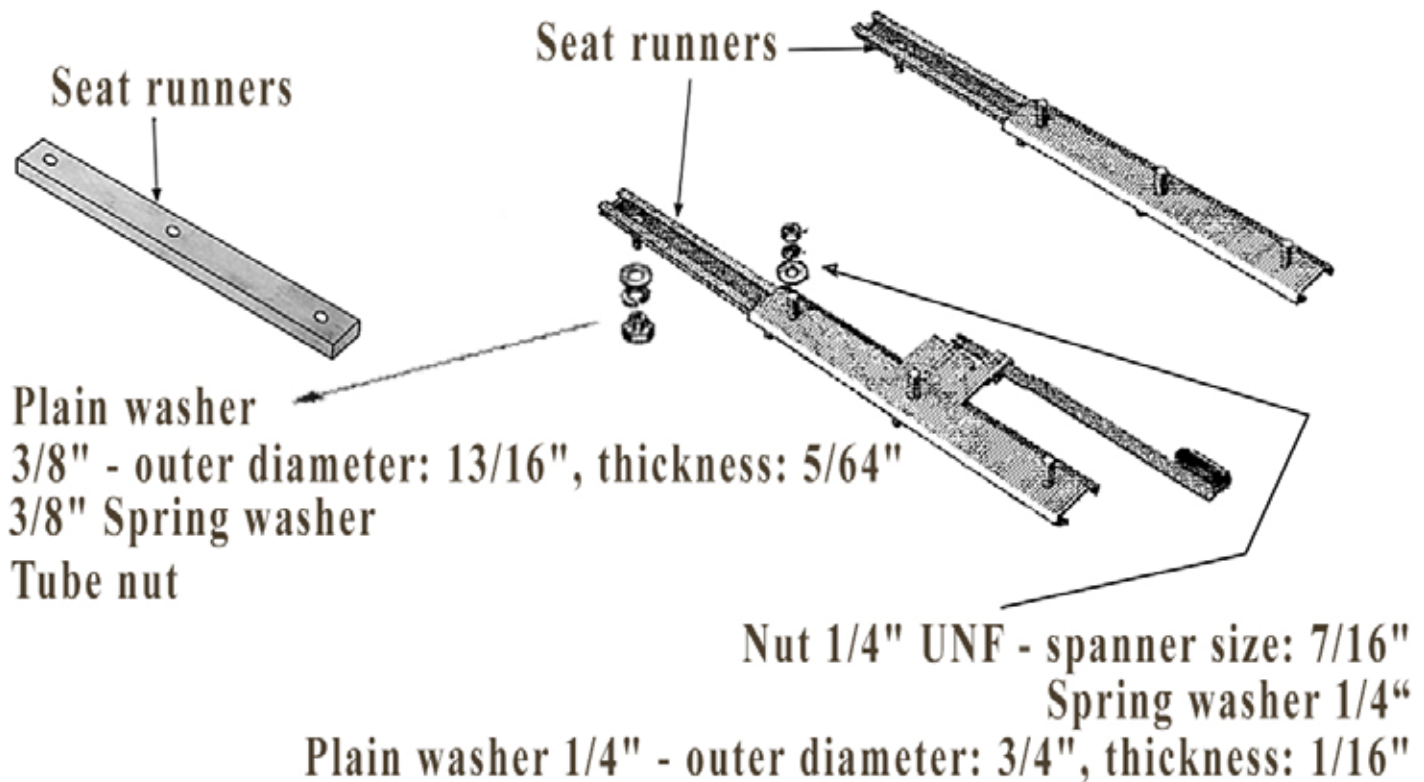

Lots of Healeys I sit in have a common problem – the seat tracks are frozen solid or take a lot of effort to move. It seems that the passenger side is worse, perhaps because it gets moved less often. Do you want your seats to glide like they are supposed to? Do you want people to get in you car and feel comfortable being able to move the seats around and you don't have to make excuses. New seat rails aren't cheap, about \$90.00 a pair.

This Tech article, will explain how to repair and refurbish your seat rails so they glide into position with no effort at all. The seat rail repair is a simple job that can be done with just basic tools that you already have. First remove the seat bottom and then the six nuts that hold the seat back on. Now jack up the car and from below remove the six bolts that hold the seat rails in. The passenger side is easier – no exhaust pipes to contend with. Under the rails are a piece of wood and a sheet metal strip save them if you can. Once the rails are out determine how much you have to take them apart. If really frozen or if some bolts are broken you should separate the top and bottom rails. To do so put the seat rail in a vice and knock the pins out of the bottom rail using a nail punch, then remove the 8 ball bearings (four per end) by sliding them out the ends. Now the two rails can be separated. Wire brush or sand blast the rails to clean them up. To replace broken bolt on the top rail use a grinding wheel to grind the head down on the inside and then what's left of the bolt on the outside. Once flat put in a vice and use the nail punch to knock out the bolt. On the bottom rail you can not get the grinding wheel inside so ground down the bolt as far as you can and use the nail punch to knock it out.

To replace the bolts find a bolt of the right length and threads and grind down the head till it is about the thickness of a quarter. Now find a friend with welding equipment or ask your gas station guy to tack it in place. The seat rails were originally cad plated a silver color, so a little silver paint should be a close match. Use some white lubricating grease on the rails and the adjusting mechanism and put two ball bearings in one side of a rail then wiggle the rail to insert the other two on the same end. Masking tape on the ends of the rails can help keep them in place. Now reinsert the retaining pin and hammer into place. Do that for the other side and your done. Reinstallation is, as the repair manual says, " a reversal of removal". The wood piece is 3/8" thick if you have to replace yours and is wood colored. The sheet metal piece goes under the wood, and now is a good time to scrape and paint the floorboard in this area prior to bolting it all back together.





2017 Encounter • Princeton, NJ

MEMBERS CORNER

By Rick Brodeur

*North Jersey
Alan & Nina Harris
Ridgewood, NJ
'63 BJ&*

If you have a problem receiving the Flash, please contact me.

Our member lists are available to any member just for the asking. Each Region President has a copy that can be distributed or I can send out a copy to any member who requests one. My email address for the Club is membership@austin-healey-stc.org . If you have any questions about your membership please contact me. Contacting me is the quickest way to solve a membership problem. My phone number and email address are on the inside front page of the Flash and on the web site.

WEBSITE INFORMATION

If you haven't signed up to the website you should so you can get access to member-only content. When you sign up on the website as a member I'll get an email. Within a day or two I'll verify you're a member and authorize access to the member only area which includes the current and past Flash newsletters. When you log in to the site you will be at the Home page. If you want to add information about yourself, change password, etc. you go to the 'profile' page by clicking on 'The Austin Healey Sports & Touring C...' in the grey bar at the top of the page.



Regalia Online Store

The AHSTC club has started a new way to get Bling. We have set up with a vendor who has all our logos. Click on the link below and Buy,Buy,Buy

<https://ahstc.qbstores.com>

Questions/concerns contact: Harrison Roberts Email: harrison220@msn.com



K&T VINTAGE SPORTS CARS

6584 Ruch Road, Bethlehem, Pa.



**NOW OPEN
IN OUR NEW LOCATION!**



DETAILS ONLINE ktvintagecars.com



Ken Beck, Owner
www.ktvintagecars.com 484-281-8085

TREASURED

MOTORCAR SERVICES

EST. 1980

RESTORATION - CUSTOMIZATION
PERFORMANCE - MAINTENANCE
SALES & CONSIGNMENT
PAINT & BODY
TRANSPORT

MECHANICAL

12340 OWINGS MILLS BLVD
REISTERSTOWN, MD 21136
410-833-2329

PAINT & BODY

3051 MONROE ST
MANCHESTER, MD 21102
443-507-4140



WWW.TREASUREDMOTORCARS.COM

Encounter Update Reminder

For the past 45 Encounters we have always met in August.

This year 2018 it is different.

Encounter is in September

September 19 Wednesday to the 23rd Sunday

Hotel info

DoubleTree Resort By Hilton
2400 Willow Street Pike
Lancaster, PA 17602

*To reserve call 717-464-2711 and mention "Austin Healey"
to get the event room rate.*

*Our special rate of \$119 + taxes per room per night is
guaranteed only through August 20, 2018.*



DELIVERING THE BEST
SINCE 1948



Al Moss
Race Car Driver, Wrench,
Parts Supplier & Raconteur
1927 - 2012

Al Moss founded Moss Motors to supply his friends and fellow enthusiasts with what they needed to keep their cars on the road. Almost 70 years later, we're proud to carry on that special legacy.

THIS IS WHO WE ARE



SAME DAY SHIPPING

FREE CATALOGS

TECH SUPPORT

EAST & WEST COAST WAREHOUSES



800-667-7872
MossMotors.com



ENCOUNTER 2018 SCHEDULE PLANNER (Exact times and events subject to change)

| | | |
|--|--------------------|---------------------------|
| Wednesday, September 19 | | |
| Registration Open | 2:00 PM | Lower Lobby |
| Wheatland Tour | 5:30 PM | Leave from DoubleTree |
| | | |
| Thursday, September 20 | | |
| Registration Open | 9:00 AM- 5:30 PM | Lower Lobby |
| Hospitality Room Open | 11:00 AM - 5:00 PM | William Penn |
| Rally School | 12:00 PM | Robert Fulton |
| Rally | 1:00 PM | |
| Welcome Reception / Charity Auction | 7:00 PM | Statesman A-B |
| | | |
| Friday, September 21 | | |
| Registration Open | 9:00 AM - 5:30 PM | Lower Lobby |
| Hospitality Room Open | 10:00 AM - 5:00 PM | William Penn |
| Bus to downtown Lancaster Central Market, Walking Tour | 9:30 AM - 1:30 PM | Leave from DoubleTree |
| Tech Session | 10:00 AM | Robert Fulton |
| ENCOUNTER Open Golf Tournament | 2:00 PM | Willow Valley Golf Course |
| Gymkhana | 1:00 PM | Lancaster Harley Davidson |
| PA Dutch Buffet / Valve Cover Racing | 6:30 PM | Statesman A-B |
| | | |
| Saturday, September 22 | | |
| Registration Open | 9:00 AM - 1:00 PM | Lower Lobby |
| Hospitality Room Open | 10:00 AM - 5:00 PM | William Penn |
| Funkhana | 9:30 AM | TBD |
| Concours Judging | 9:00 AM | Rear |
| Popular Car Show Voting | 12:00 PM - 3:00 PM | South Lot |
| Tech Session | 3:00 PM | Robert Fulton |
| AHSTC Board Meeting | 3:00 PM | TBD |
| Cocktails (Cash Bar) | 6:00 PM | Palm Court |
| Awards Banquet | 7:00 PM | Palm Court |
| | | |



September 19-22, 2018
DoubleTree by Hilton
Lancaster, PA

Did you know.....?

Lancaster Central Market and Wheatland, home of President James Buchanan, are among the 10 top things to do in Lancaster, according to TripAdvisor. And that both of those attractions are part of the ENCOUNTER agenda.

#3



#4



74

Is the average high temperature in Lancaster from September 19-22

SO WHAT ARE YOU WAITING FOR?

REGISTER TODAY!

ENCOUNTER 2018

REGISTRATION FORM DETAILS

Wednesday Evening Private Tour of Historic Wheatland - This private AHSTC guided tour is FREE for the first 35 registrations (number of people per registration) received by July 1. If space is available after July 1, additional people are \$12 per person.

Friday Morning Trip to Downtown Lancaster - This trip includes bus to historic Central Market and a Walking Tour of Downtown featuring notable and historic buildings and architecture. Lunch on your own at any of the many restaurants in the downtown area. Cost for this trip is \$15 per person and includes the bus transportation and walking tour.

Friday evening PA Dutch Buffet Dinner - Our Friday evening meal will give you a taste of Lancaster County PA Dutch cooking and includes such favorites as Chicken Pot Pie, Pork & Sauerkraut, Mashed Potatoes and, of course, Shoo Fly Pie! Following the meal, Valve Cover Racing will be held inside.

Saturday Night Awards Banquet - Dinner selections for the banquet are:

Thyme & Rosemary Roasted Chicken Breast

Garlic & Thyme Marinated Flat Iron Steak

Horseradish & Garlic Encrusted Salmon

****Dietary Restrictions for Both Meal Events**- Please communicate special dietary requirements for both Friday and Saturday evening dinners to us by checking VEG when submitting the registration form so we may make appropriate alternate arrangements.

Kids Meals - For both Friday and Saturday evening dinners, children ages up to age12 have the option of Chicken Fingers, Spaghetti, or a Hamburger and Fries. Children 4 and under are free for both meal events.

Concours Instructions - All Concours entrants must contact Don Schneider and submit their entries NO LATER than August 19. In addition all cars must current 2018 inspection sheets and a fire extinguisher. Judging fee of \$120 is selected on registration form.

Golf Event - There will be fun golf event on the 9 hole course at the hotel. We are still developing the details, but the event will be held on Friday afternoon. Cost/Green fees will be payable at ENCOUNTER. If you're interested in playing, please indicate the number of people participating.

Event Logo Polo Shirt - White, cotton/poly, polo shirts with the ENCOUNTER logo will be only be available by pre-order on the registration form. Men's and Ladies sizes are available.

HOTEL - Our reserved room block at the ENCOUNTER rate is guaranteed through August 19, 2018. Make sure to book your hotel room as soon as possible even if you're not sending in your ENCOUNTER registration yet.



Austin Healey Sports & Touring Club

ENCOUNTER 2018

September 19 - 22, 2018 in Lancaster, PA

(www.AHSTC.org)

Last Name _____ First Name _____ Spouse/Guest _____
 Street _____ Apt.# _____
 City _____ State _____ Zip _____
 Phone – Home(____)(____) Cell(____)(____) Is this your 1st Encounter? (Y/N) _____
 Attending Children's Names & Ages _____
 Region/Club Affiliation _____ E-Mail Address _____

Car(s) You Are Bringing to the Event:

1. Model _____ Year _____ 2. Model _____ Year _____ 3. Model _____ Year _____

Registration Instructions

1. Complete registration form
2. Make check payable to "AHSTC Encounter"
3. Enclose both in an envelope and mail to:

Encounter Registration
 Mary Ann Waltz
 845 Pheasant Road
 Harrisburg, PA 17112-1330
 (717)-671-4573
 maw845@aol.com

Registration Fee Includes:

- One show car, 2 adults, and children (under 21)
(Additional cars/adults on a single registration are extra)
- Free access to our hospitality room for the weekend
- Free flea market space
- Free admission to all tech sessions and driving events

Hotel Information

DoubleTree Resort By Hilton
2400 Willow Street Pike
Lancaster, PA 17602

To reserve call 717-464-2711 and mention "Austin Healey" to get the event room rate.

Our special rate of \$119 + taxes per room per night is guaranteed only through **August 20, 2018.**

Concours Information

Cars to be judged MUST contact Don Schneider at dschneid@ptd.net for instructions by Aug. 19 and have their 2018 judging packet 30 days prior to the event.

Expected arrival date: 9/19 9/20 9/21 9/22

Will you need flea market space? Yes / No

Will you need regalia space? Yes / No

Will you need trailer parking? Yes / No

PLAY IN FRIDAY PM GOLF TOURNAMENT? # of people _____

Registration Fees

\$65 if postmarked by July 1, 2018 \$ _____
 \$75 if postmarked after July 1, 2018 \$ _____
 Extra cars @ \$10 each \$ _____
 Extra adults (over 21) @ \$20 each \$ _____

Wed. evening private tour of historic Wheatland, home of President James Buchanan. FREE with first 35 registrations received by July 1, 2018.

No. of People- _____

If space available after July 1, \$12 p/person \$ _____

Friday 9/21 Trip to Downtown Lancaster Including Central Market & Walking Tour

___ No. of people @ \$15 each \$ _____

Fri 9/21 PA Dutch Dinner**
 ___ No. of adults @ \$35 each \$ _____

___ No. of children 6-12 @ \$20 ea. (Kids Meal \$14) \$ _____

___ No. of children 5 and under No Charge

Sat 9/22 Awards Banquet**

Adults @ \$45 each \$ _____

Chicken ___ Beef ___ Fish ___ Veg ___

Children 6-12 @ \$25 each (Kids Meal \$14 ea.) \$ _____

Chicken ___ Beef ___ Fish ___ Veg ___

Children 5 and under No Charge

Chicken ___ Beef ___ Fish ___ Veg ___ Kids ___

****See Page 2 for Special Diet & Kids Meals for these events**

Chinese Auction Tickets – 7 for \$5 \$ _____

Concours Judging Fee @ \$120/car \$ _____

Event Logo Golf Shirts @ \$28 each \$ _____

Men's sizes

___S ___M ___L ___XL ___2XL (\$30) ___3XL (\$33)

Women's sizes

___S ___M ___L ___XL

Total Remittance (US) \$ _____

For Sale

Seat covers-BJ8. Moss black leather in very good condition. Moss foam set brand new in original packing. All for \$300. Greg 215-990-6842. GEDubas@yahoo.com

Sprite parts for sale.

Parts from a 61 Sprite fitting Bugeye and MK2 Sprites:

- Doors, windshields, trunk lids, front suspension and complete front brake drum assemblies.
- Driveshafts, sidecurtain set, 10 hole rims.
- Bugeye lightweight fibreglass hardtop.

Contact Ian Hall 610 883 7109 or Motovespa65@gmail.com

I am an owner of an Austin Healy 3000, MK1, BT-7. It's been restored. I am trying to find someone who might be **interested in buying some left over original parts** I've had for years. The largest and most complex is a complete engine and transmission. They would need a total work up and restoration but all of the parts are there. Thanks Rich Hollenbush hollenbu@cs.com

My father in law passed away, and we are looking to sell the 1966 Austin Healy Mark III. The car is dismantled and was in the process of being professionally restored Is anyone interested ?

Thanks John jsts@optonline.net

Thanks to the great friends and members of the AHSTC my "wanted to buy list" has become considerably smaller.

Looking for a 100-4 battery cover panel. Thank you, stmiller96@hotmail.com

Bugeye parts

Wire Wheel conversion *(62 Midget suspension and wheels) \$100.00

NOS Amco console \$250.00

NOS Amco floor mats, blue, 4 pieces with aluminum frame rail covers \$ 100.00

NOS Amco grill guard \$250.00

NOS BMC blue Tonneau \$350.00

Fabric Side Curtains , one NOS, one used \$200.00

Top Frame, early 1958, no springs \$150.00

**WW Conversion , pick up only at zip code 21131.

All other parts, Encounter 2017 delivery possible.

Clint Becker • 410-371-3188 cell or whitesprite59@gmail.com

Parts for sale - Need to make room in the garage !

- **Convertible top boot for BJ8. Black vinyl, decent condition. \$65**
- **Heater blower motor, de rusted, painted. \$40**
- **Shipping at cost.**

Mike Jennings mgjenn1@gmail.com 301 266 6367

Pair of solid useable Bugeye seats complete, \$500.

Pair of Bugeye seat frames and metal curved seat backs. Bit rough but saveable. \$125.

WANT TO BUY

Decent MG1100. Running or non running.

Contact Ian Hall, motovespa65@gmail.com • 610 883 7109.



For Sale

1969 Sprite for sale. Needs complete restoration; includes many extra parts. I have too many other projects. \$500 or best offer. (717)469-1047. Email alanmende@yahoo.com.



Wanted

60 Bugeye needs a bonnet and seat bottoms.
Contact Gary Hoehing at posa371@yahoo.com

Original 1950-70s dealership or auto parts store signs related to foreign sports cars. Also looking for original advertising posters from 1950-60s sports car races or hill climbs. Mike Putignano • mputs2000@yahoo.com

100-4 full set of gauges
motor mounts
front fenders
handbrake handle

100-6 BN6
Front shroud
cockpit combing
disc wheel rear brake drum
disc wheel front hub assembly

Contact Paul Serdiuk at pis9@yahoo.com



OVER 300 HEALEY'S RESTORED FIXED PRICE RESTORATIONS



BIG HEALEY'S WANTED any condition!

RESTORATIONS, SALES, SERVICE, PERFORMANCE UPGRADES

Healey 5 Speed, Hendrix Wire wheels, Kilmartin Chassis replacements



British Restoration Corp.

2231 East Ontario Street

Philadelphia, PA 19134

Cell: 917.257.3410

Office: 215.291.9666

www.britishrestorationcorp.com

Directory

CORPORATE PRESIDENT

Ray Donovan
215-699-8355

president@ahstc.org

CORPORATE MEMBERSHIP

Rick Brodeur
215-536-6912

membership@austin-healey-stc.org

CORPORATE SECRETARY

Del Border
717-235-1086

delborder@comcast.net

HARRISBURG REGION

President

Joe Spear
717-272-8343

bjspear1@verizon.net

Editors

Fred Bennett
(717) 635-8083

Quitewaterpaddler@gmail.com

Meetings

3rd Tuesday, 6:30PM

Watch E-Flash
for Location

LEHIGH VALLEY REGION

President

Ken Beck

kenbeck@rcn.com

Editor

Gerry Kunkle

agkunkle@aol.com

Meetings

3rd Monday

Watch E-Flash
for Location

PHILADELPHIA REGION

President

John Heffron
215-300-4023

john.heffron@hotmail.com

Editor

Randy Alkins
215-343-2785

randyalkins@gmail.com

Meetings

3rd Monday, 7pm

Metropolitan DIner

BRANDYWINE REGION

President

Chuck Ott
302-378-7287

chucknsueo@yahoo.com

Editor

Ernie Lesser
410-398-7308

ernstleser@verizon.net

Meetings

Watch E-Flash for Date,
Time & Location

NORTH JERSEY REGION

President

Steve Feld
973-206-1973

stevenergy@optonline.net

Editor

George Crombie
908-243-0693

george_crombi@yahoo.com

Meetings

Watch E-Flash for Date,
Time & Location

LONG ISLAND REGION

President

Paul Parfrey
718-353-8138

workshealey@aol.com

Editor

Paul Parfrey
718-353-8138

workshealey@aol.com

Meetings

Watch E-Flash for Date,
Time & Location



CONTRIBUTIONS

AHSTC encourages the submission of articles to the Editor for publication. There is no restriction on content, other than it should be of interest to the readership and Healey related.

MEMBERSHIP & SUBSCRIPTIONS

The AHSTC is a non-profit, Pennsylvania corporation dedicated to the preservation of the Austin Healey marque. Contact Rick Brodeur or a region president to inquire on membership.

ADVERTISEMENTS

25 word, non-commercial classified ads run for 3 months and are free to members. Non-member classified rates are \$0.20 per word. Commercial Advertisers please contact Bob Ott at 610-657-6688 or rsott9@gmail.com

NEWSLETTER DEADLINE

Contributions & advertising must be received by the editor prior to the 25th of each month for inclusion in the following month's issue.

CONTRIBUTING EDITORS

Send contributions and ads to Steve Jekogian stevejekogian1@gmail.com

DISCLAIMER:

The Austin-Healey Sports & Touring Club, its Board and members assume no responsibility for the accuracy of advertisements listed in this issue of The Flash.

Technical Articles that appear on this site are the opinion of the authors and do not necessarily reflect the views of the AHSTC. Products and Services advertised on this site are not necessarily endorsed by The Austin-Healey Sports & Touring Club, its Board or membership. Complaints or inquiries should be forwarded directly to the advertisers.

All purchases are at the complete discretion of the consumer